

MAX
190x80

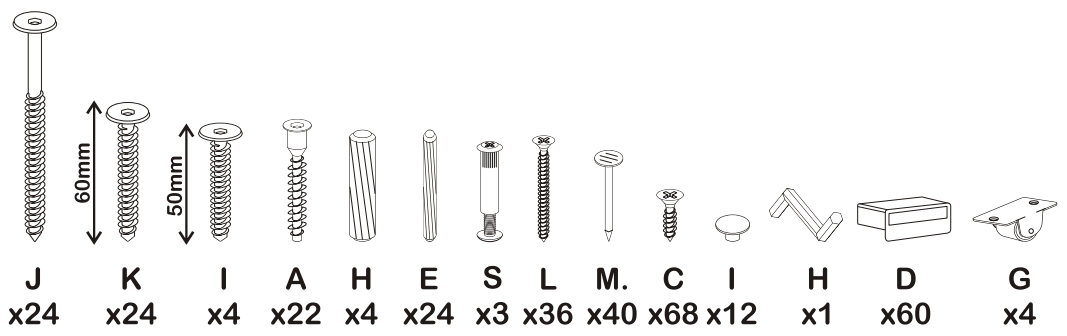

1

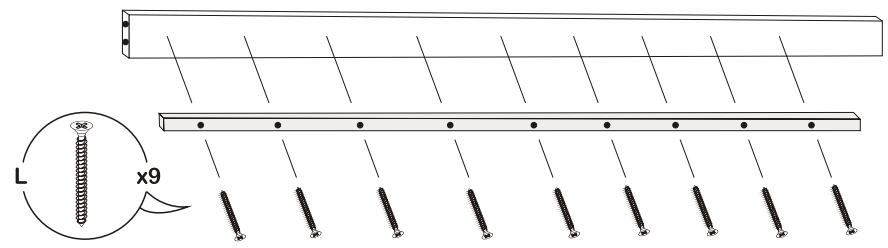

2

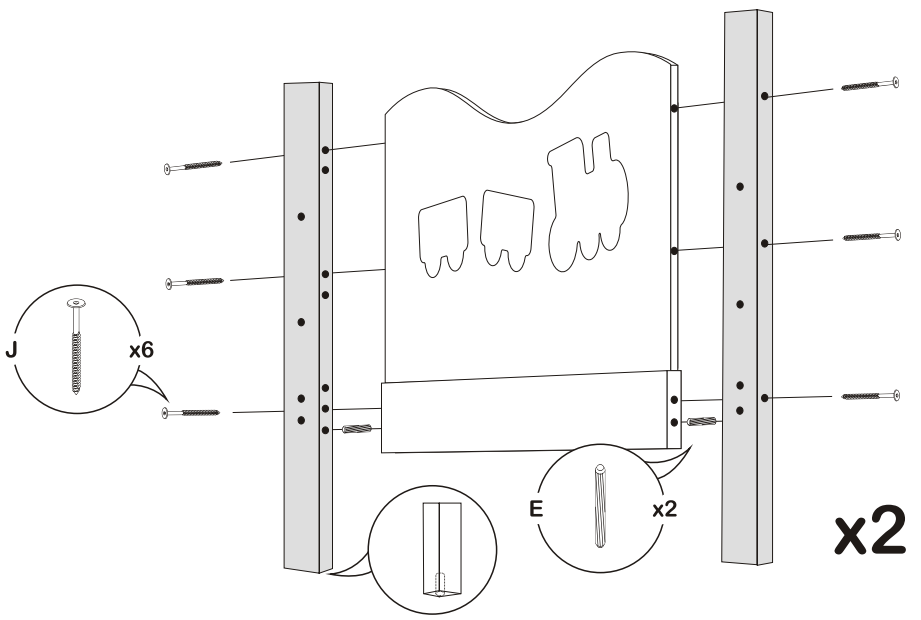

3

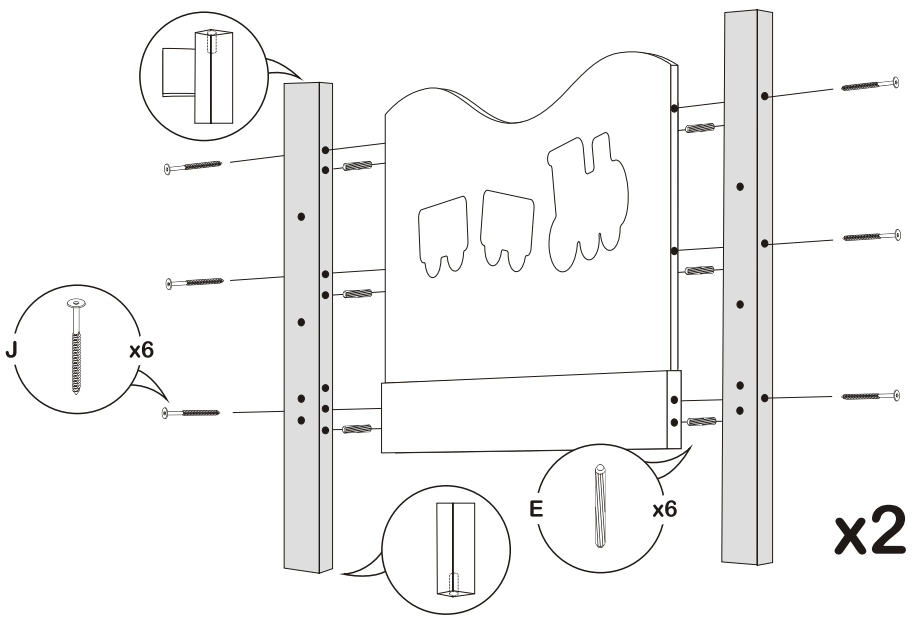

4

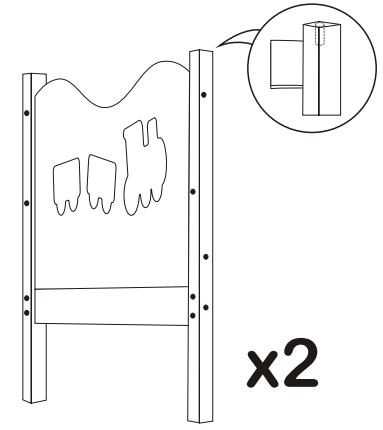

5

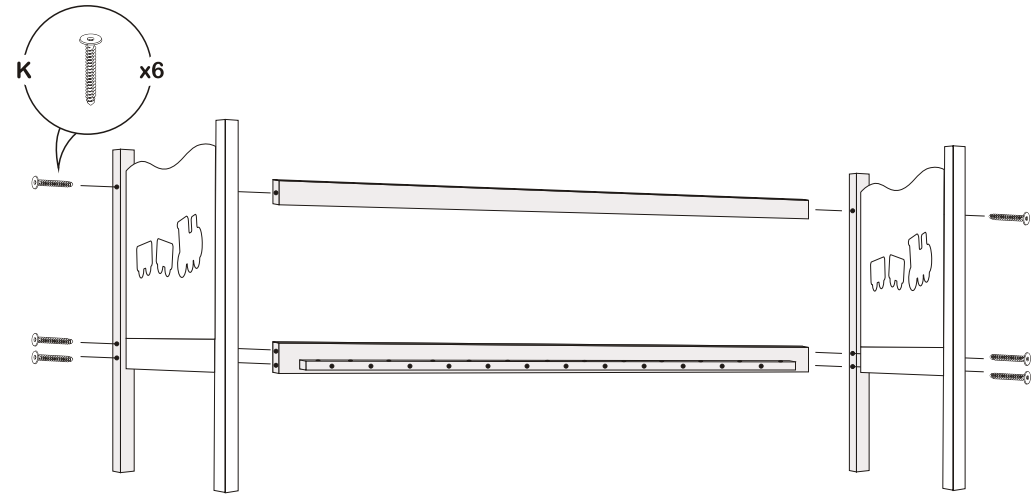

6



7

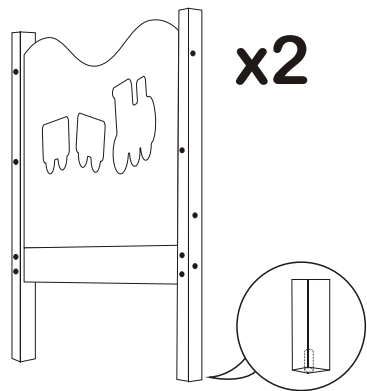

x2

8

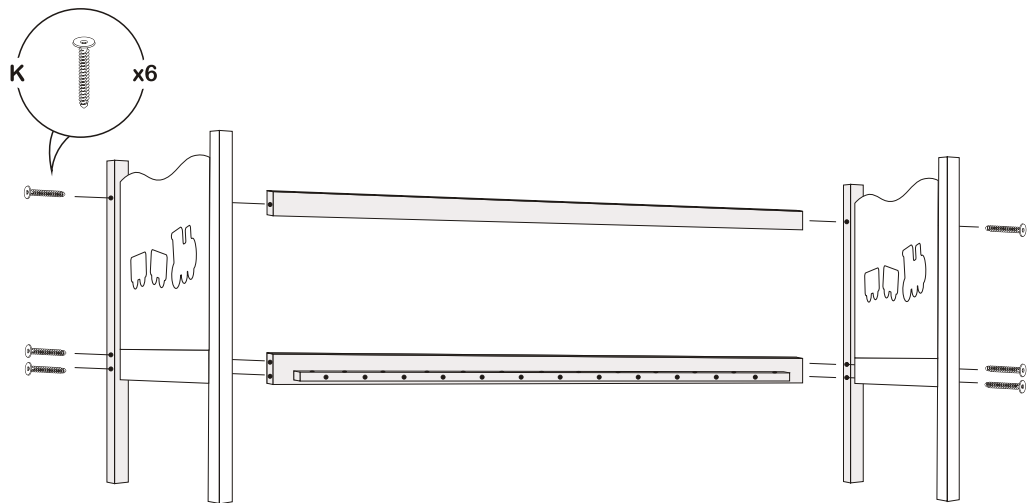

x6

9

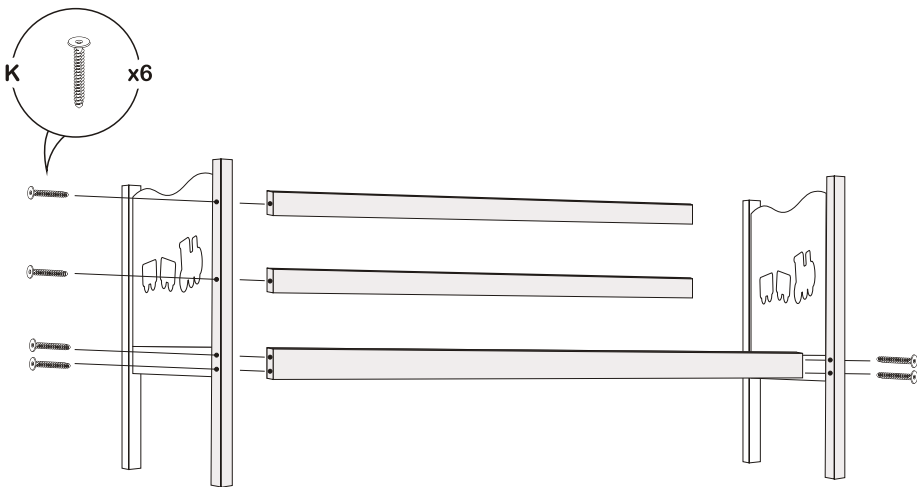

x6

10

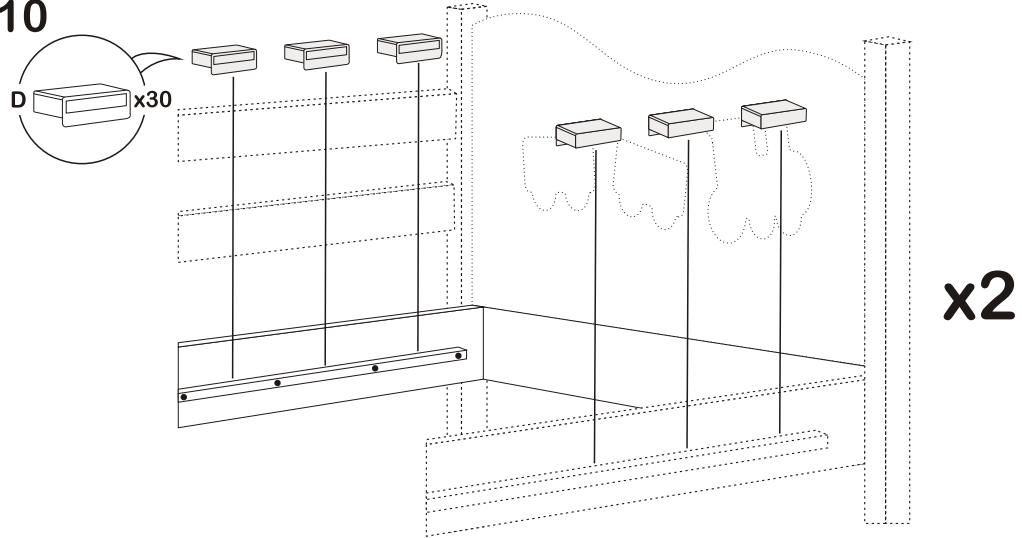

D x30

x2

11

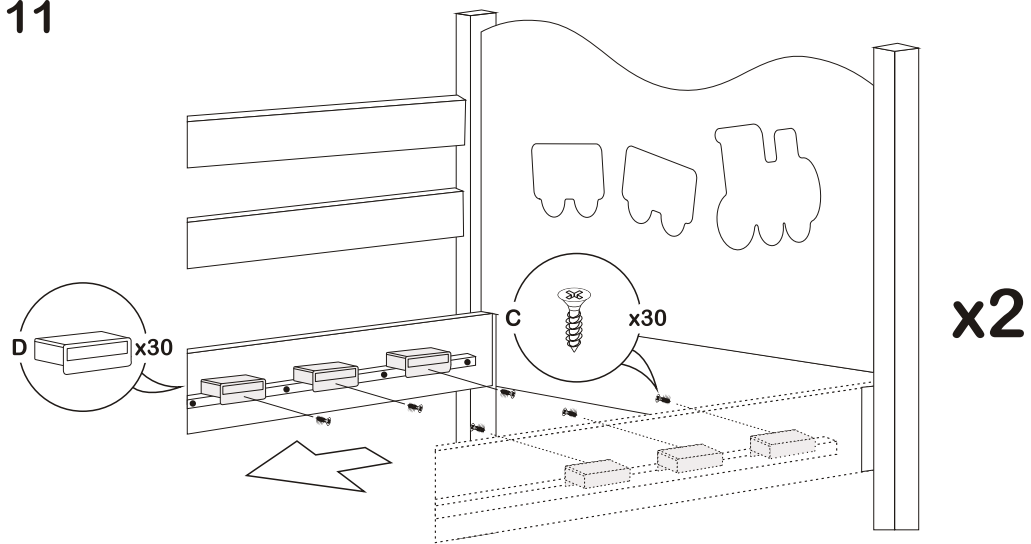

C x30

D x30

x2

12

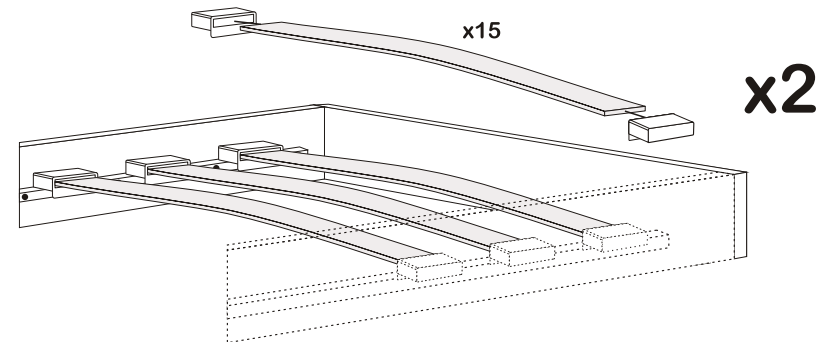

x15

x2

13

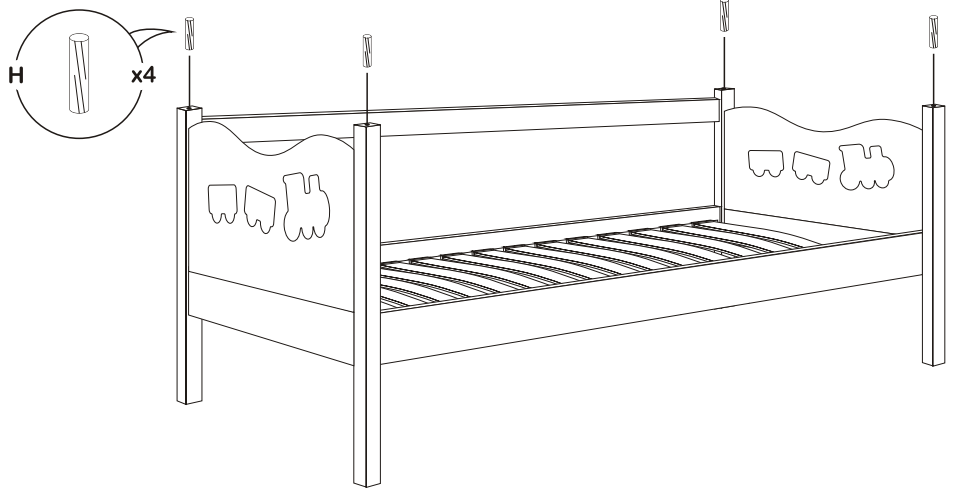

14

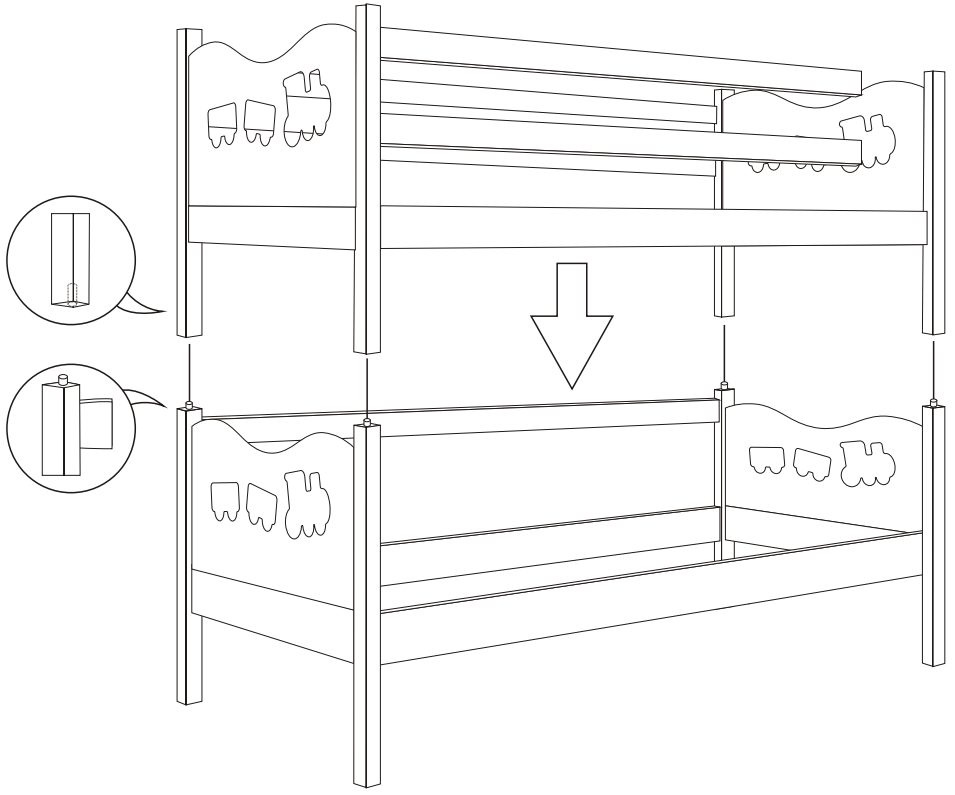

MAX for 3 person

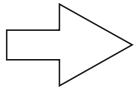

go to step 24

15

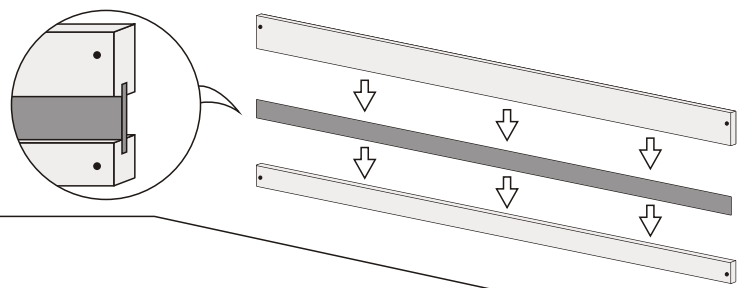

16

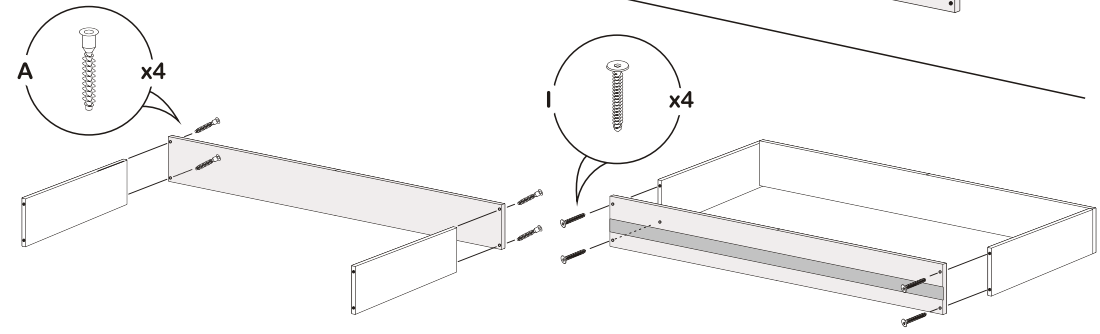

17

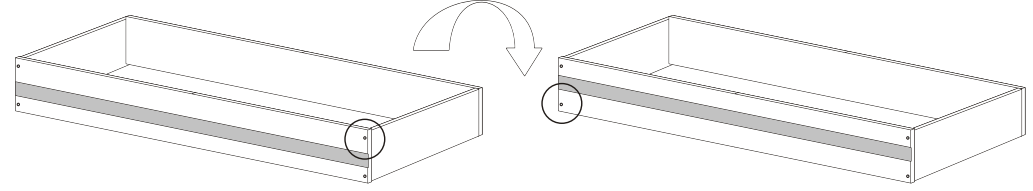

18

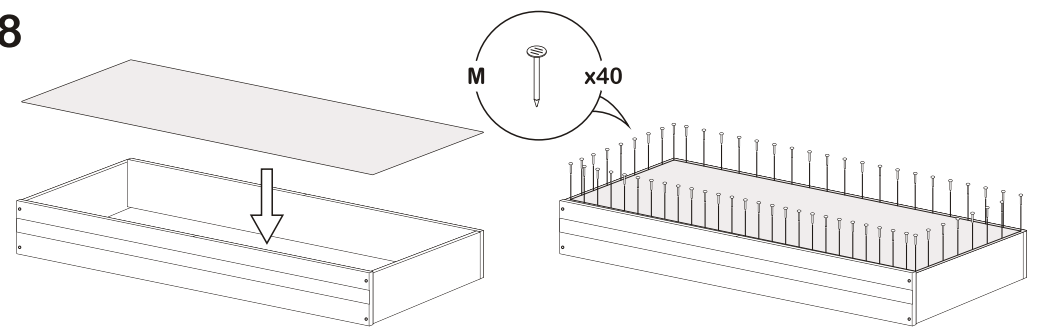

19

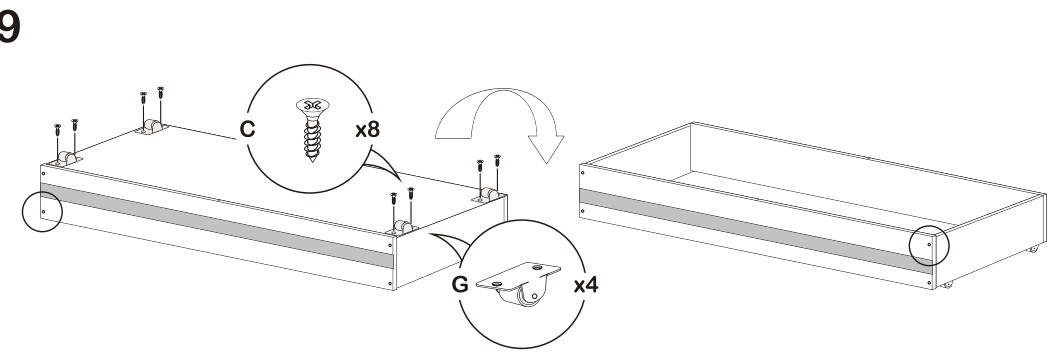

20

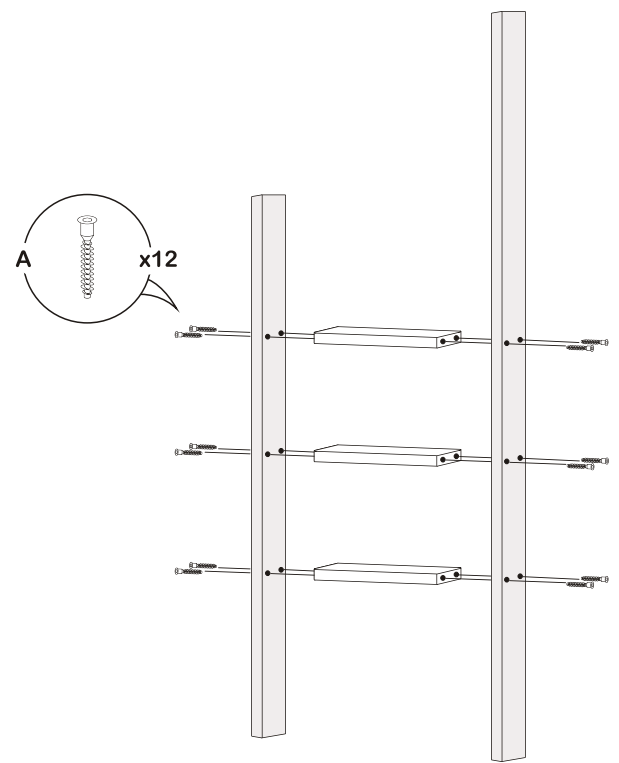

22

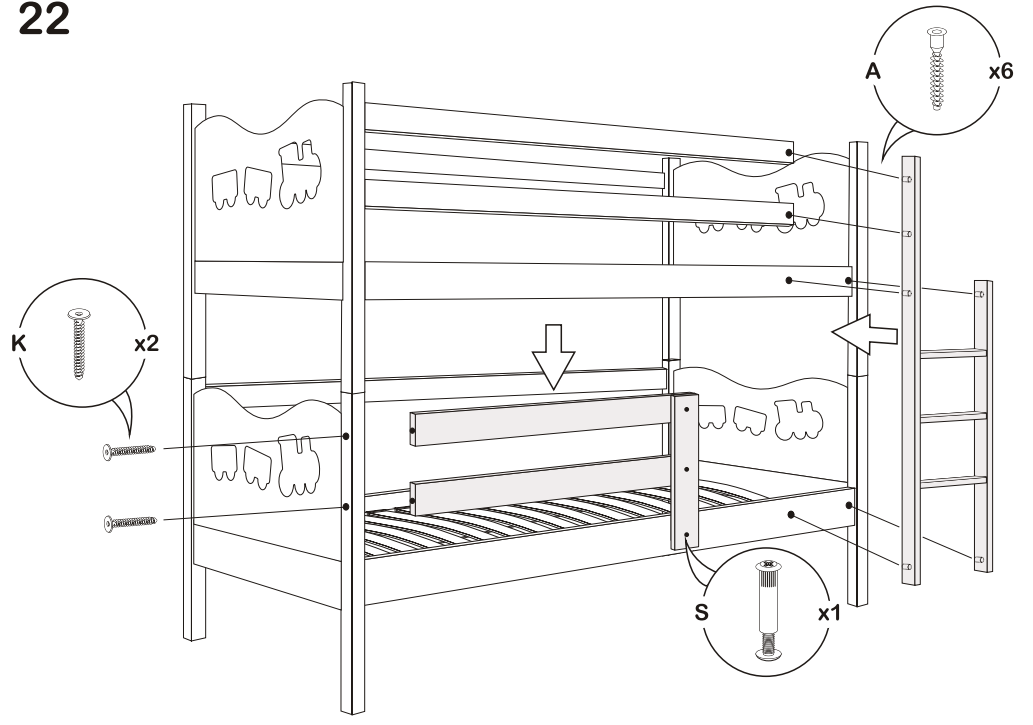

21

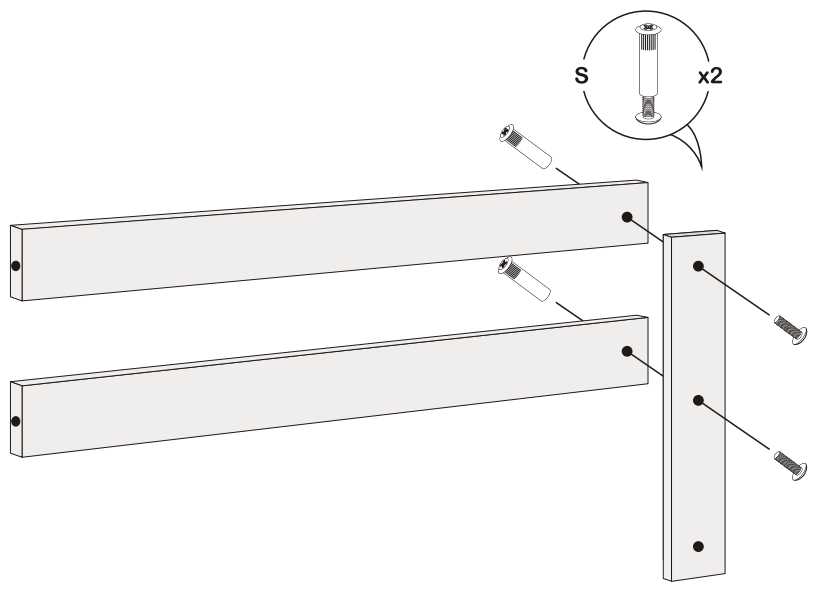

23

