

20451C

9220TABA

PARISOT INDUSTRIE 70800 SAINT LOUP SUR SEMOUSE -FRANCE-

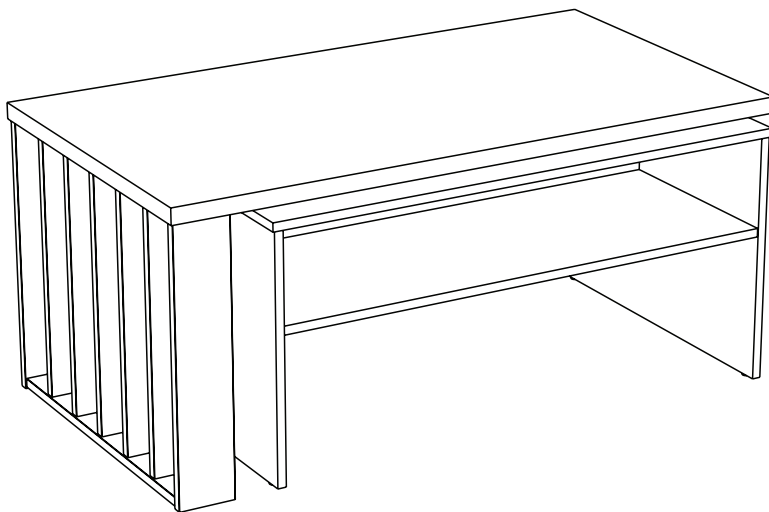

Gamme : NALA

PARISOT INDUSTRIE

FR Remerciements :

Nous vous remercions d'avoir choisi un meuble créé et fabriqué par le Groupe Parisot et espérons qu'il vous donnera entière satisfaction.

EN Thanks:

Thank you for choosing furniture designed and manufactured by the Parisot Group. We hope you are totally satisfied with your purchase.

DE Danksagung:

Wir danken Ihnen für den Kauf eines Frankreich von der Parisot-Gruppe entworfenen und hergestellten Möbelstücks und hoffen, dass Sie es zu Ihrer vollkommenen Zufriedenheit finden werden.

HU Köszönet:

Köszönjük, hogy a Parisot Groupe által létrehozott és gyártott bútort választott, reméljük, hogy elégedett lesz a termékkel.

PT Agradecimentos:

Obrigado por ter escolhido um móvel concebido e fabricado pelo Grupo Parisot, esperando que seja do seu inteiro agrado.

IT Ringraziamenti:

Grazie per avere scelto un mobile progettato e fabbricato dal Gruppo Parisot. Speriamo soddisfatti appieno le vostre esigenze.

NL Bedankje:

Wij bedanken u voor de aankoop van een door de Groep Parisot ontworpen en vervaardigd meubel en hopen dat u er veel plezier aan zult beleven.

CZ Poděkování:

Děkujeme, že jste si vybrali nábytek navržený a vyrobený společností Parisot Group. Doufáme, že budete svým nákupem naprosto spokojeni.

ES Agradecimientos:

Les damos las gracias por haber elegido un mueble diseñado y fabricado por el Grupo Parisot y esperamos que sea de su total agrado.

PL Podziękowania:

Dziękujemy za wybór mebli stworzonych i wyprodukowanych przez Grupę Parisot. Mamy nadzieję, że będziecie Państwo w pełni zadowoleni z zakupu.

SK Pod'akovanie:

Ďakujeme, že ste si vybrali nábytok navrhnutý a vyrobený spoločnosťou Parisot Group. Dúfame, že budete svojim nákupom absolútne spokojení.

AR شكر:

نشكركم لاختياركم هذه القطعة من الأثاث من تصميم وتصنيع مجموعة باريسو Parisot ونتمنى أن تتال رضاءكم.

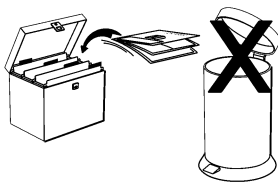

FR

Donnez ou recyclez vos meubles.



ou



ou



Association

Magasin

Déchèterie

<https://quefairedemesdechets.fr>

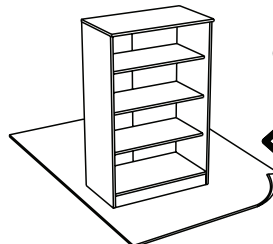
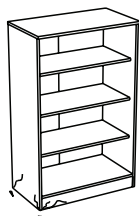
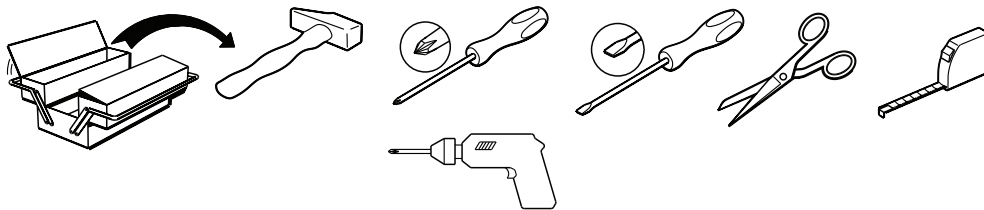

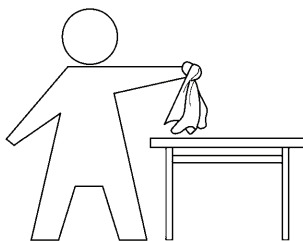

- FR: INSTRUCTIONS GÉNÉRALES POUR LE MOBILIER CONSTITUÉ DE BOIS OU DE COMPOSITES DE BOIS (COMME LES SURFACES EN MELAMINÉ, STRATIFIÉ OU PLACAGE)**
Nettoyer à l'aide d'un chiffon humide. Utiliser uniquement de l'eau ou un détergent doux. Essuyer à l'aide d'un chiffon propre.
- EN: GENERAL INSTRUCTION FOR FURNITURE MADE OF WOOD OR WOOD COMPOSITES SUCH AS MELAMINE, LAMINATE OR VENEER SURFACES!**
Wipe clean with a damp cloth. Use only water or a gentle detergent. Wipe dry with a clean cloth.
- DE: ALLGEMEINE ANWEISUNGEN FÜR MÖBELPFLEGE AUS HOLZ ODER HOLZVERBUNDWERKSTOFFEN (WIE MELAMIN-, LAMINAT- ODER FURNIEROBERFLÄCHEN)**
Mit einem feuchten Tuch reinigen. Verwenden Sie nur Wasser oder ein mildes Reinigungsmittel. Mit einem sauberen Tuch abwischen.
- HU: ÁLTALÁNOS ÚTMUTATÁS A FÁBÓL KÉSZÜLT VAGY ÖSSZETETT FAANYAGOT, PÉLDÁUL MELAMIN-, LAMINÁLT VAGY FURNÉRFELÜLETET TARTALMAZÓ BÚTOROKKHOZ**
Törölje tisztára nedves ruhával. Csak vizet vagy kímélő tisztítószert használjon. Törölje szárazra tiszta ruhával.
- PT: INSTRUÇÕES GERAIS PARA OS MOVÉIS DE MADEIRA, LAMINADO, MELAMINA E FOLHEADO.**
Limpar com um pano húmido, utilizar apenas água ou detergente doce. Limpar com um pano seco
- IT: ISTRUZIONI GENERALI PER MOBILI IN LEGNO O MATERIALI COMPOSITI IN LEGNO (COME SUPERFICI IN MELAMINICO, LAMINATO O IMPIALLACCIATO)**
Pulire con un panno umido. Utilizzare solo acqua o un detergente delicato. Asciugare con un panno pulito.
- NL: ALGEMENE INSTRUCTIES VOOR MEUBELS VERVAARDIGD UIT HOUT OF HOUTCOMPOSITIET ALS MELAMINE, LAMINAAT OF FINEEROPPERVLAKKEN!**
Reinig met een vochtige doek. Gebruik alleen water of wasmiddel. Droogwrijven met een schone doek
- CZ: OBECNÉ POKYNY TÝKAJÍCÍ SE NÁBYTKU VYROBENÉHO ZE DŘEVA NEBO Z KOMPOZITŮ DŘEVA, NAPŘ. S POVRCHEM Z MELAMINU, LAMINÁTU NEBO DÝHY!**
Čistíte otřením navlhčeným hadříkem. Používejte pouze vodu nebo jemný čistící prostředek. Vytřete dosucha čistým hadříkem.
- ES: INSTRUCCIONES GENERALES PARA MUEBLES FABRICADOS CON MADERA, MELAMINA, LAMINADO Y CHAPA.**
Limpiar con paño húmedo. Utilizar únicamente agua o detergente suave. Secar con un paño seco .
- PL: OGÓLNE INSTRUKCJE DOTYCZĄCE MEBLI Z DREWNA ORAZ MATERIAŁÓW DREWNOPOCHODNYCH: MELAMINA, LAMINAT, OKLEINA**
Do czyszczenia należy używać wilgotnej ściereczki. Używać wyłącznie wody lub delikatnego detergentu. Wycierać do sucha ściereczką.

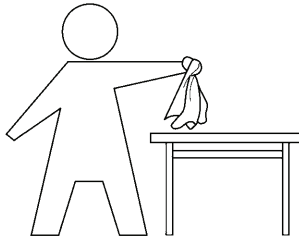

RO: **INSTRUCȚIUNI GENERALE PENTRU PIESELE DE MOBILIER REALIZATE DIN LEMN SAU DIN COMPUȘI DIN LEMN PRECUM SUPRAFEȚELE MELAMINATE, LAMINATE SAU FURNIRUITE!**
Curățați prin ștergere cu o lavetă umedă. Utilizați numai apă sau un detergent delicat.
Uscați prin ștergere cu o lavetă curată.

RU: **ОБЩИЕ УКАЗАНИЯ ОТНОСИТЕЛЬНО МЕБЕЛИ, ИЗГОТОВЛЕННОЙ ИЗ ДЕРЕВА ИЛИ ДРЕВЕСНЫХ КОМПОЗИЦИОННЫХ МАТЕРИАЛОВ, ТАКИХ КАК МЕЛАМИН, ЛАМИНАТ ИЛИ ШПОН!**
Очистите изделие чистой влажной тканью. Используйте мягкодействующее моющее средство.
Вытрите досуха чистой тряпкой.

SK: **VŠEOBECNÉ POKYNY PRE NÁBYTOK VYROBENÝ Z DREVA ALEBO KOMPOZITNÝCH MATERIÁLOV, NAPRIKLAD MELAMÍNU, LAMINÁTU ALEBO PREGLEJKOVÝCH POVRCHOV!**
Utrite dočista navlhčenou utierkou. Používajte iba vodu alebo jemný čistiaci prostriedok.
Utrite dosucha čistou utierkou.

SL: **SPLOŠNA NAVODILA ZA VZDRŽEVANJE POHIŠTVA IZ LESA ALI LESENIH KOMPOZITOV, KOT SO MELANIN, LAMINAT ALI FURNIR!**
Obrišite z vlažno krpo. Uporabljajte le vodo ali blag detergent.
Posušite s čisto krpo.

TR: **AHŞAP VEYA MELAMİN, LAMİNAT YA DA AHŞAP KAPLAMA GİBİ AHŞAP TÜREVİ YÜZEYLERDEN YAPILAN MOBİLYALARA YÖNELİK GENEL YÖNERGE!**
Nemli bir bezle silerek temizleyin. Yalnızca su veya yumuşak bir deterjan kullanın.
Temiz bir bezle silerek kurulayın.

ZH: 针对实木及实木复合类（三聚氰胺面、层板、胶合板）家具的一般说明
请用湿布擦拭。只使用水或温和洗涤剂。
请用干净的布擦干。

AR: بعامة للأثاث المصنوع من الخشب أو الخشب (مثل الأسطح المصنوعة من الميلامين أو البورنولي أو البترة) تنظف بقطعة قماش مبللة. سنحدم الماء فقط أو منظف معتدل بصبغ بقطعة قماش نصف

50cm
19 3/4"
110cm
43 1/2"
60cm
23 3/4"

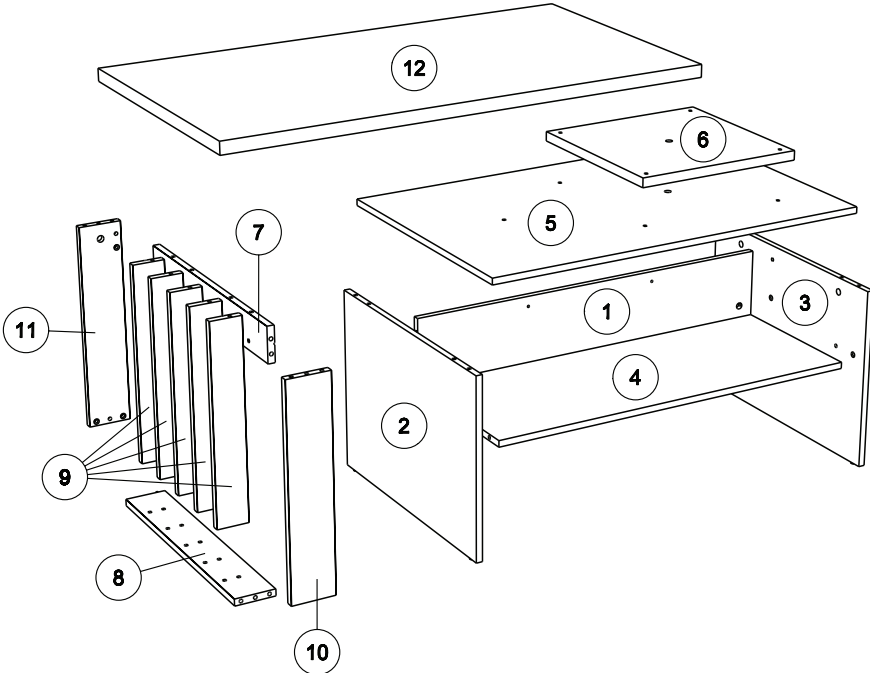

		mm			inch		
⑥	x 1	398	398	22	15 11/16	15 11/16	7/8
⑨	x 5	452	72	16	17 13/16	2 13/16	5/8
⑪	x 1	470	97	16	18 1/2	3 13/16	5/8
⑩	x 1	470	97	16	18 1/2	3 13/16	5/8
⑦	x 1	560	80	16	22 1/16	3 1/8	5/8
⑧	x 1	560	93	16	22 1/16	3 11/16	5/8
③	x 1	596	427	15	23 7/16	16 13/16	9/16
②	x 1	596	427	15	23 7/16	16 13/16	9/16
①	x 1	892	158	15	35 1/8	6 1/4	9/16
④	x 1	892	592	15	35 1/8	23 5/16	9/16
⑤	x 1	929	600	15	36 9/16	23 5/8	9/16
⑫	x 1	1100	600	28	43 5/16	23 5/8	1 1/8

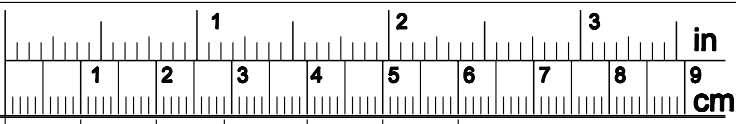

CJX x1

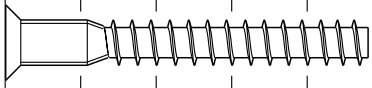

HW x3



AOJ x25

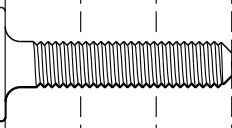
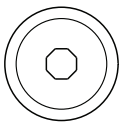

BGZ x4

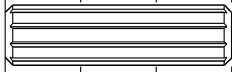

ADM x35

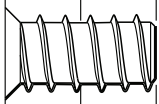

AiB x10

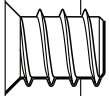

AiA x16

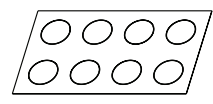

COL. x2

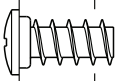

VB x4



Ai x25

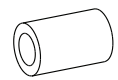

CSL x2



AKG x5

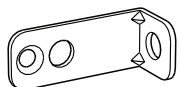

BLL x2

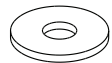

CHW x2

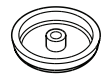

BML x4

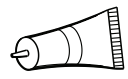

CF x1



AHZ x1

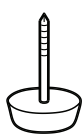

BQS x8



HV x1

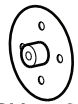

PU x6

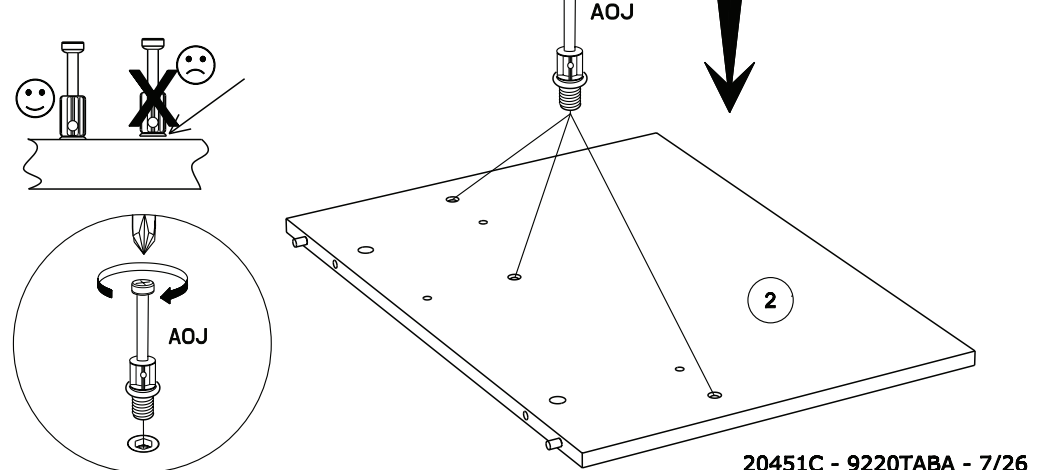
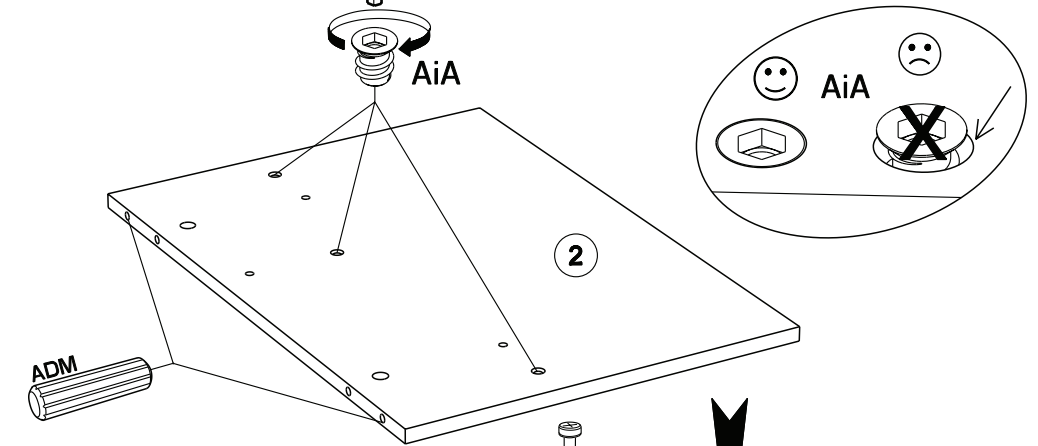
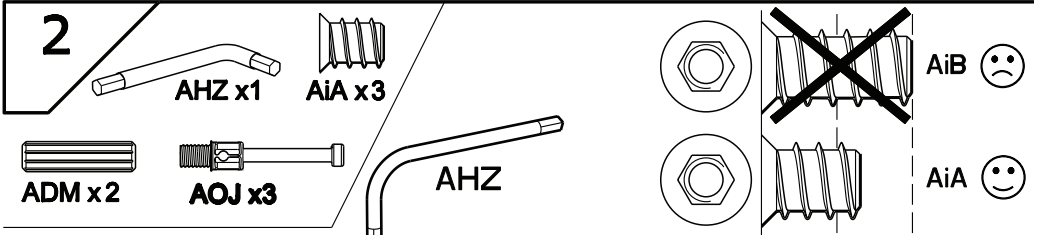
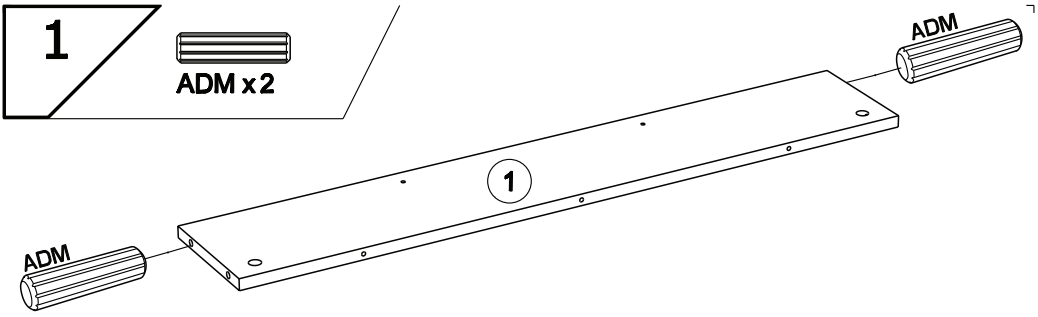

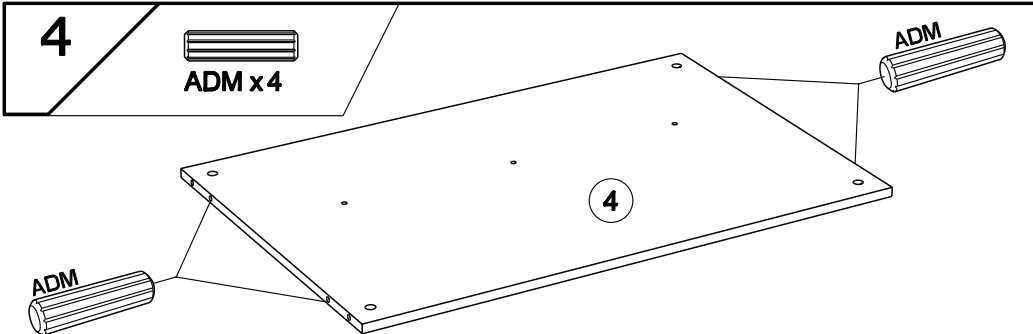
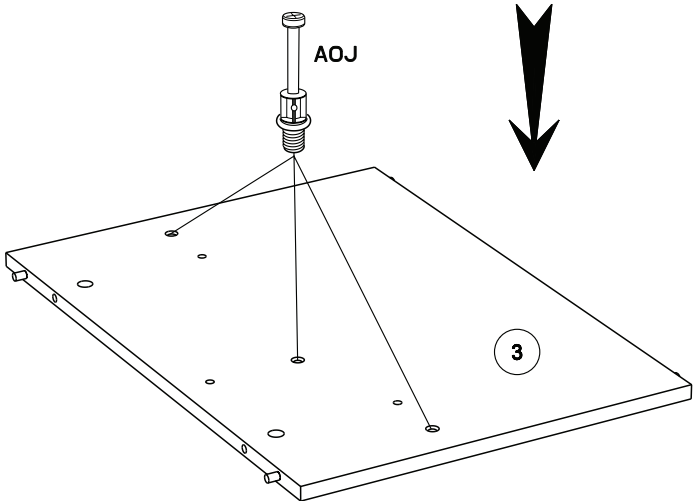
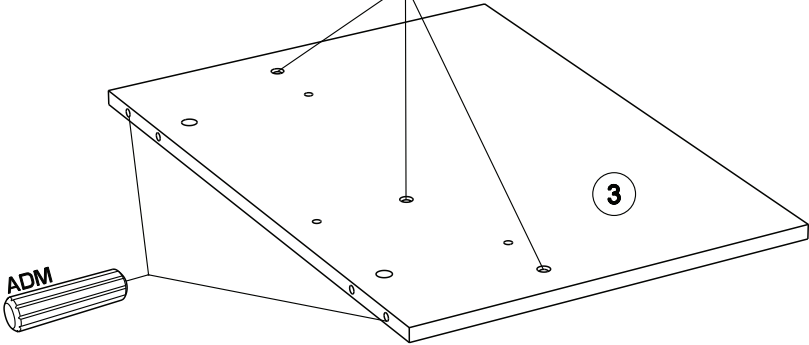
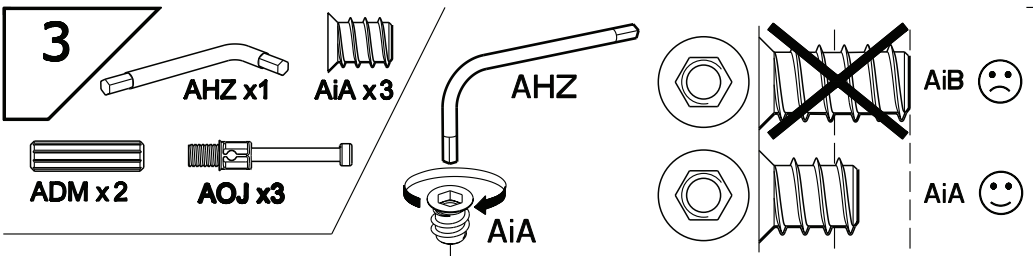

5



AHZ x1



AiA x4

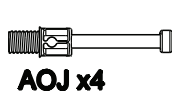

AOJ x4



VB x 2

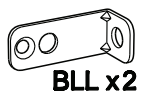

BLL x2

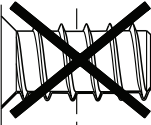

AiB ☹️

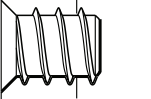

AiA 😊

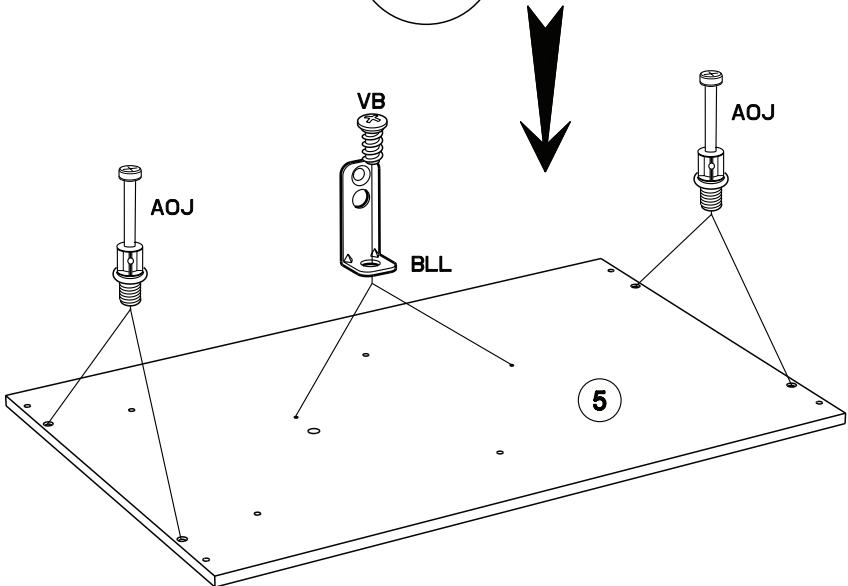
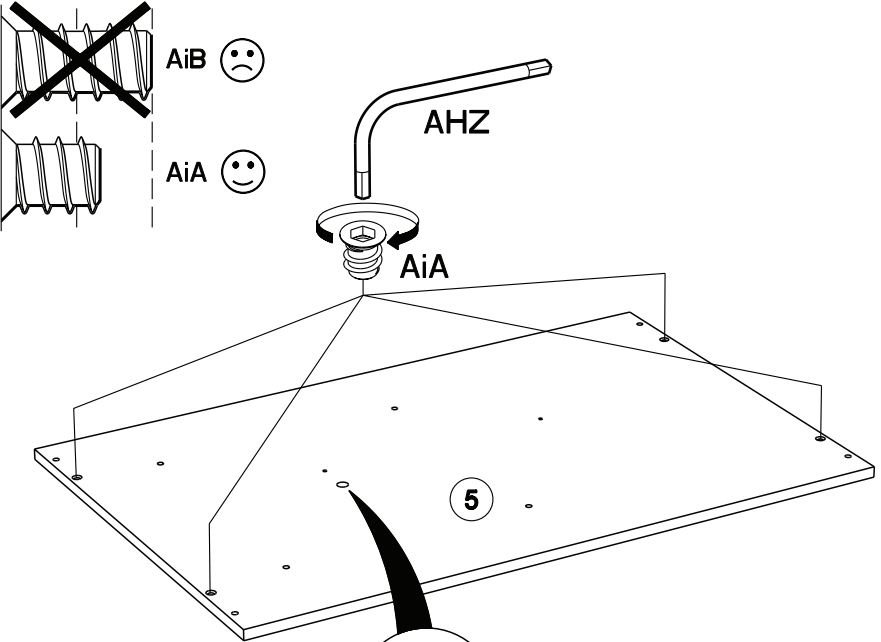

6

HW x 3

Ai x 3

HV x 1

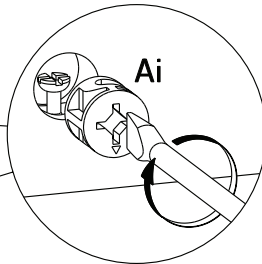
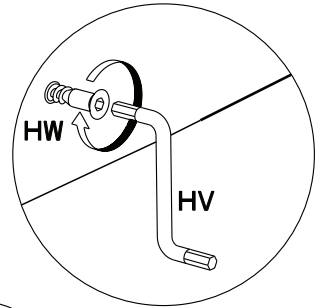
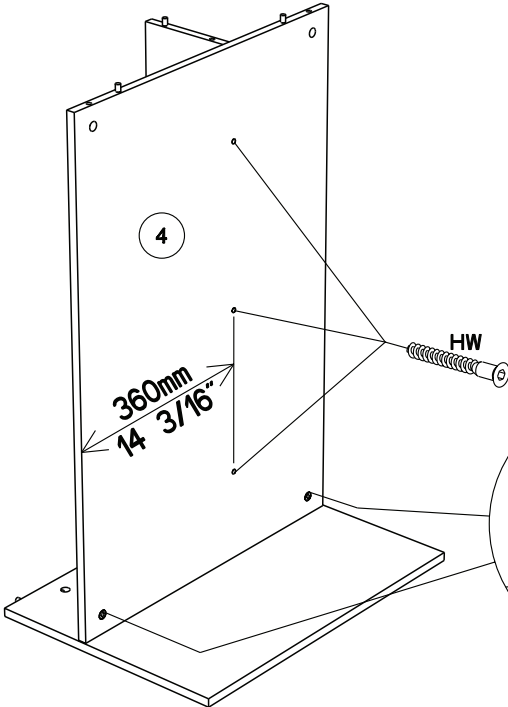
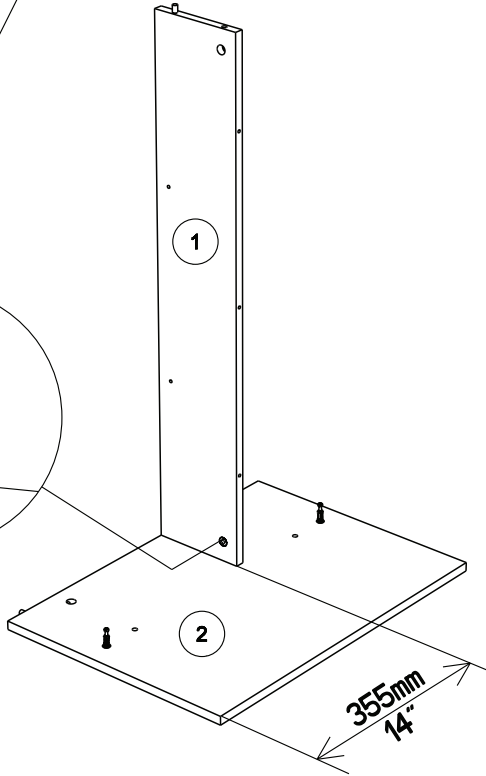

7



Ai x3

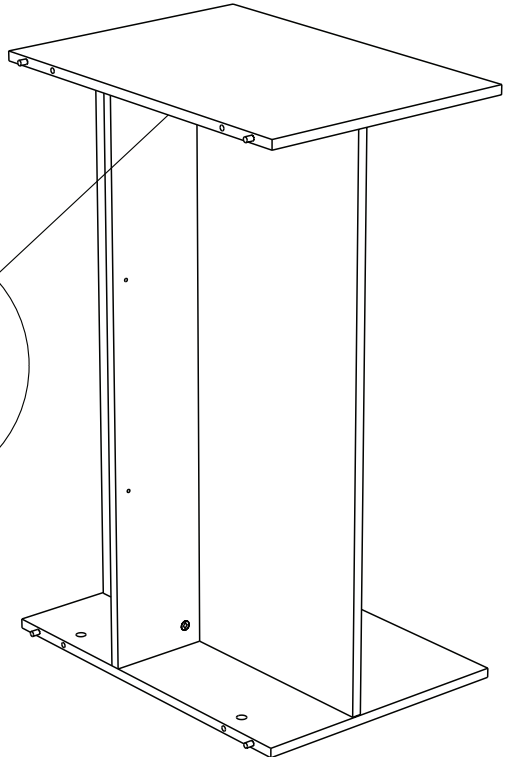
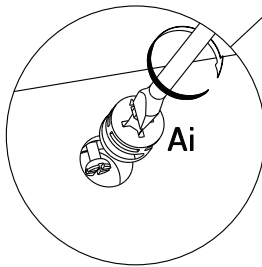
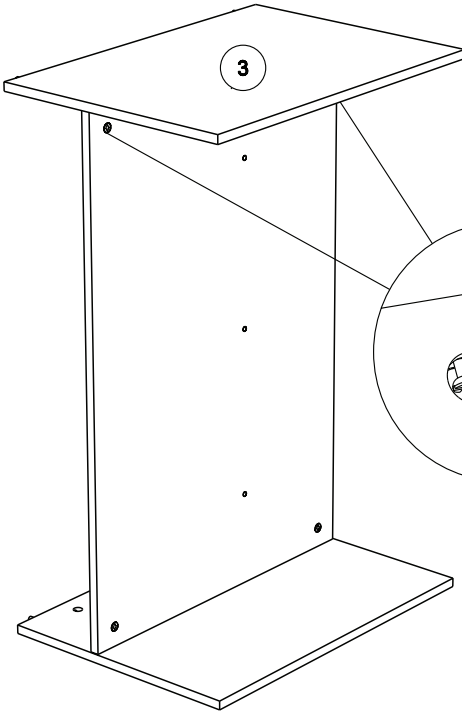

8



Ai x 4



VB x 2

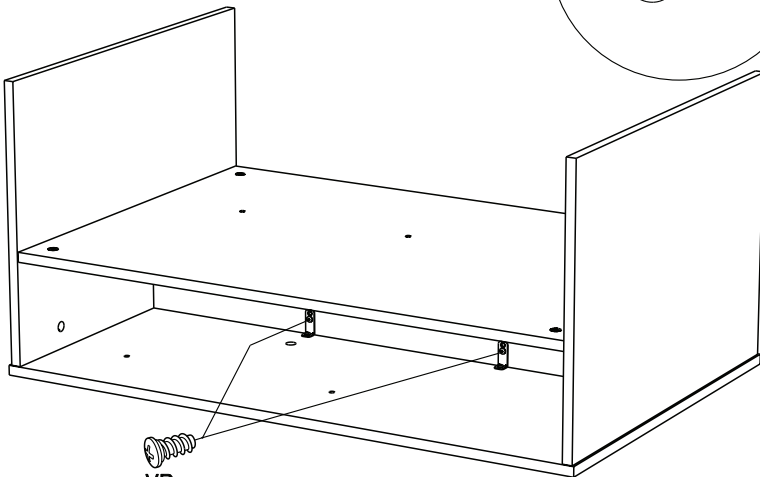
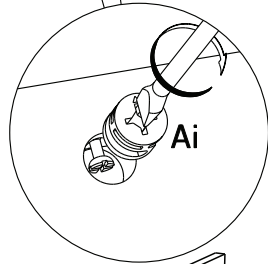
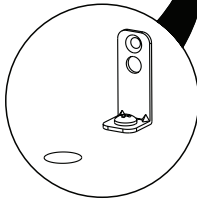
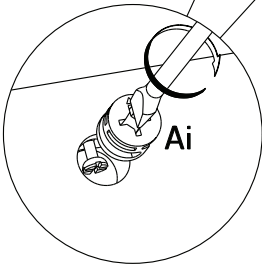
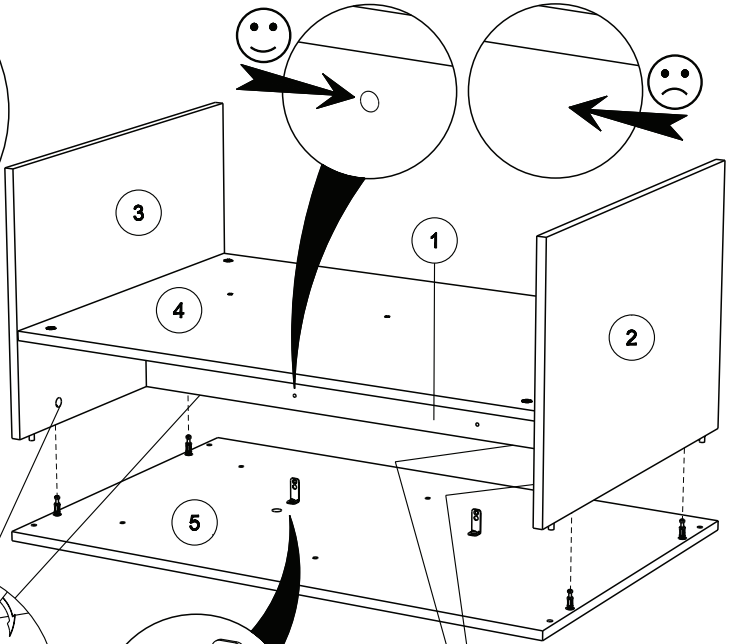

VB

9

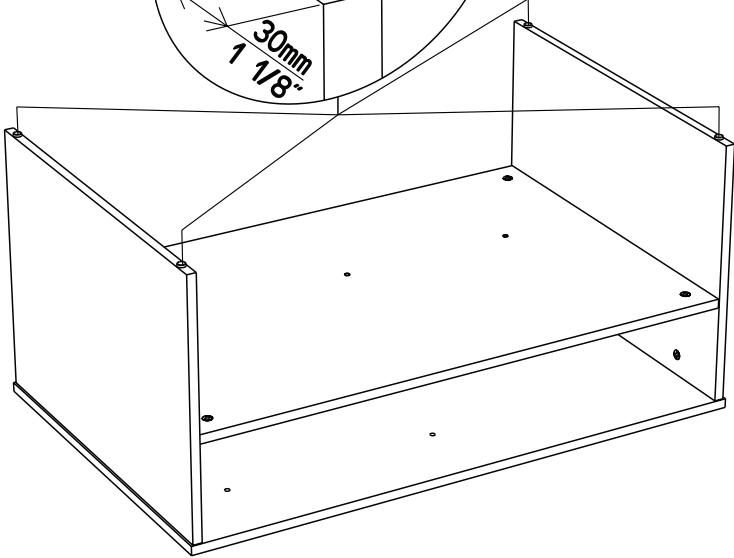
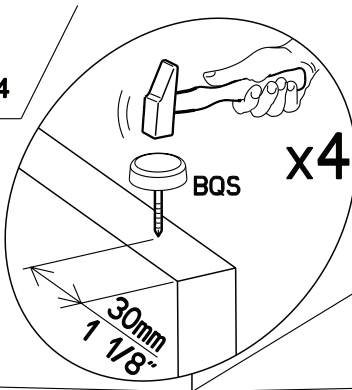

10



PU x 6

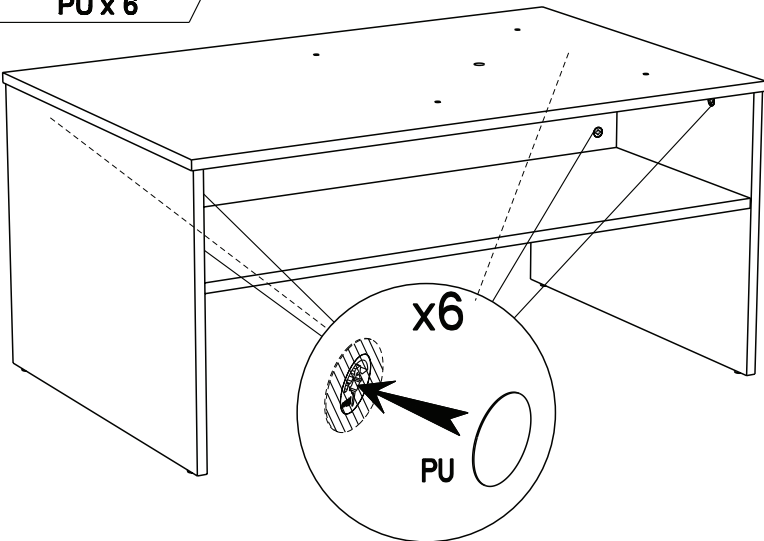

11

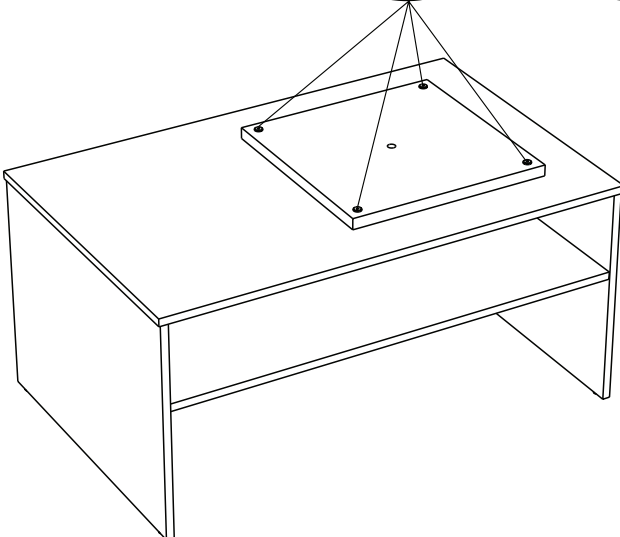
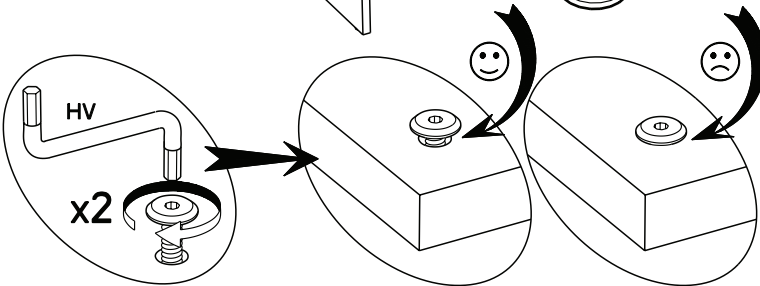
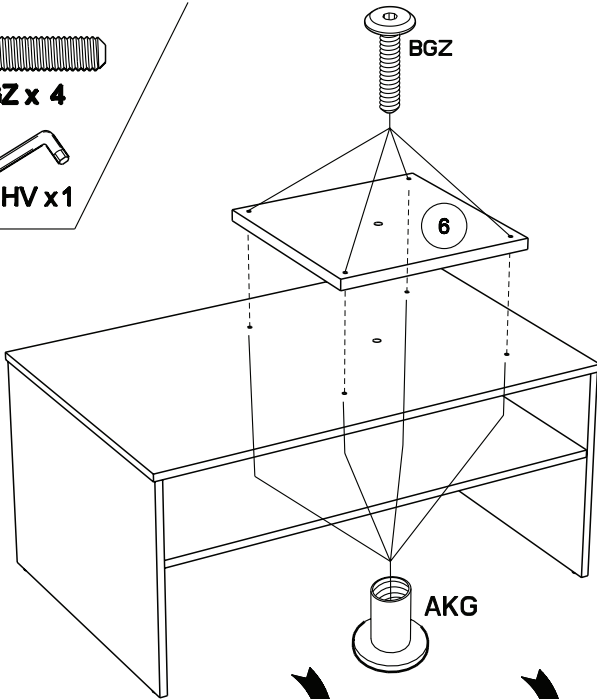

12



BML x 4



HV x1

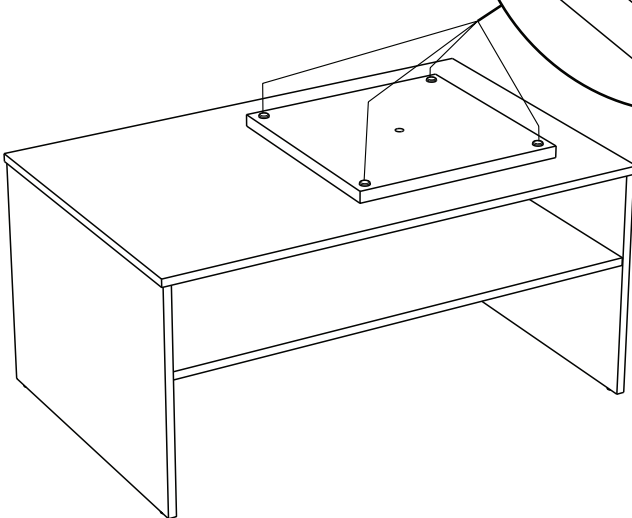
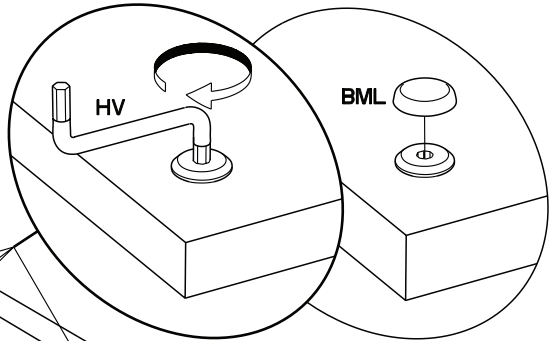
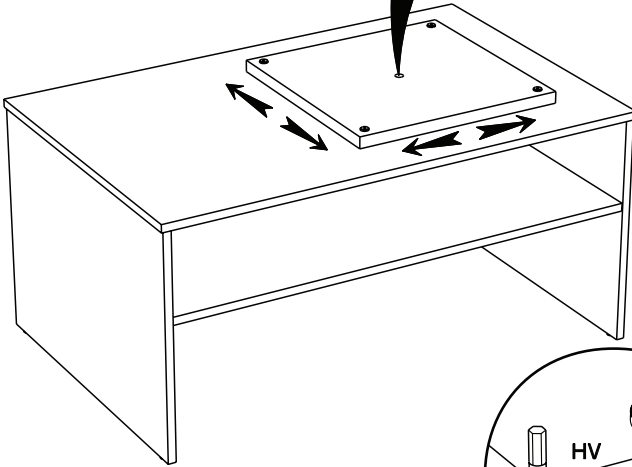
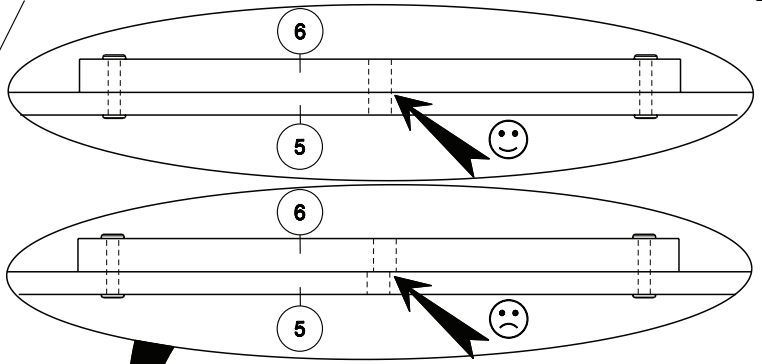

13

ADM x6

CF x1

BQS x4

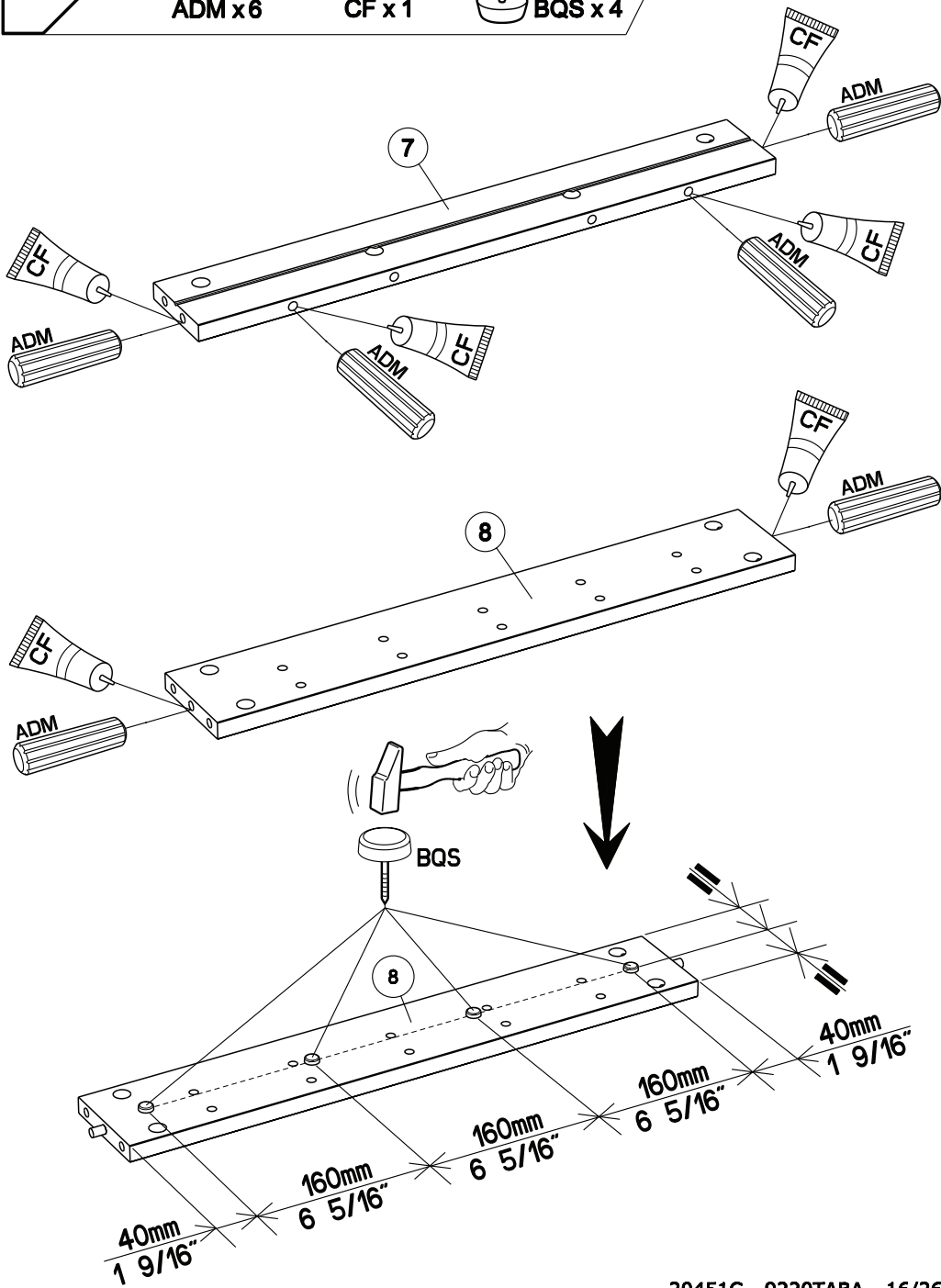

14



ADM x2



CF x1



AHZ x1



AiA x3



AOJ x3

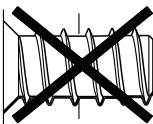

AiB ☹️

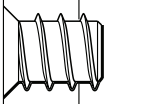

AiA 😊

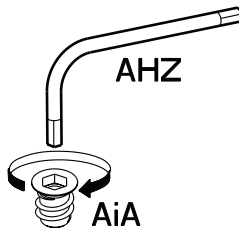

AHZ

AiA

10

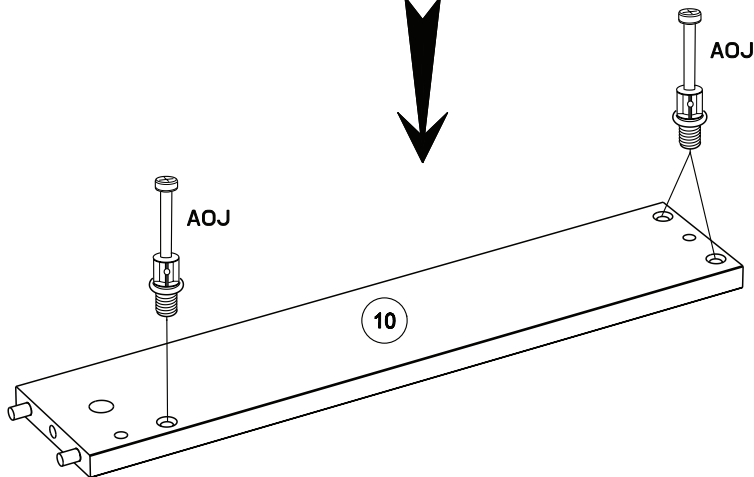
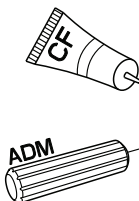

AOJ

AOJ

10

15

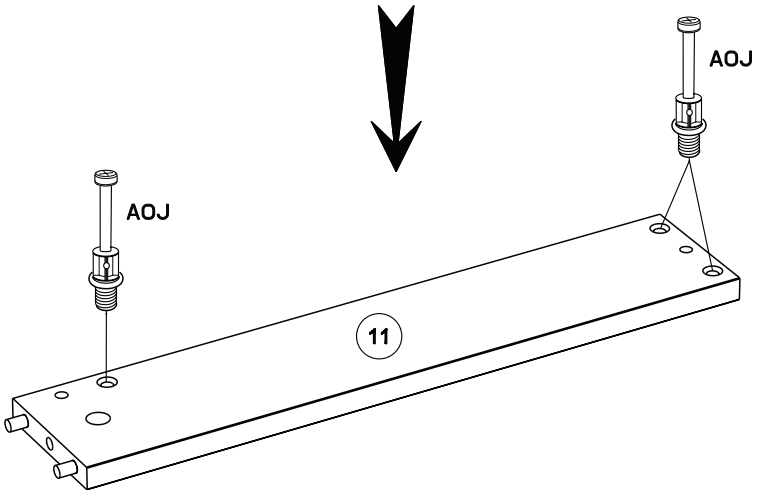
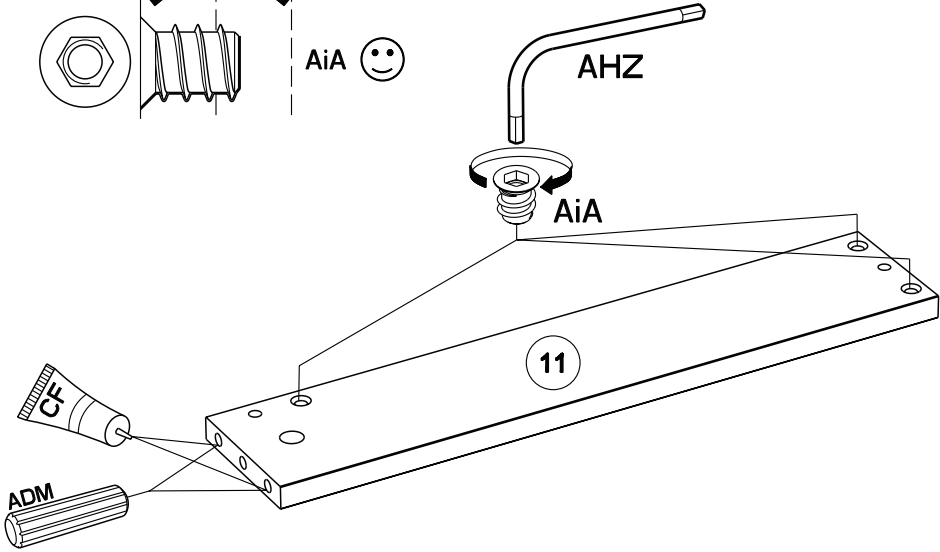
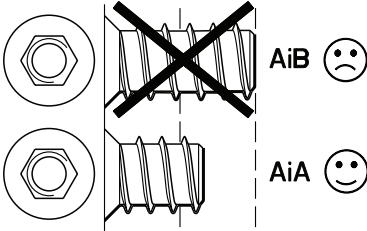
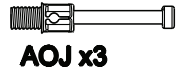

16

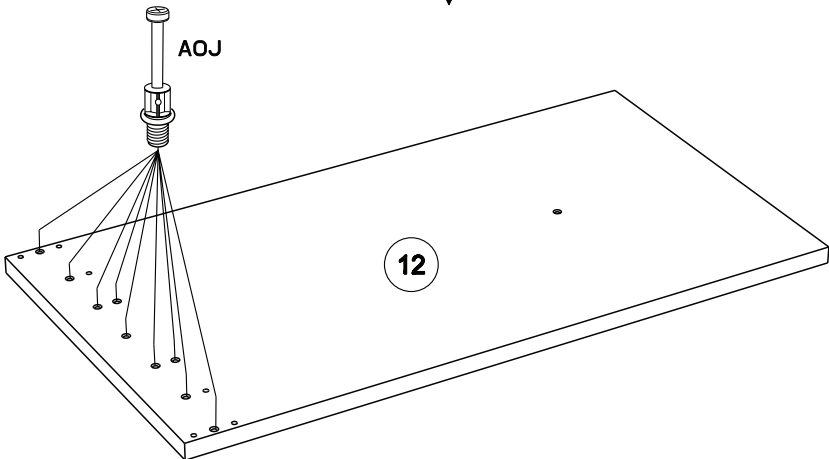
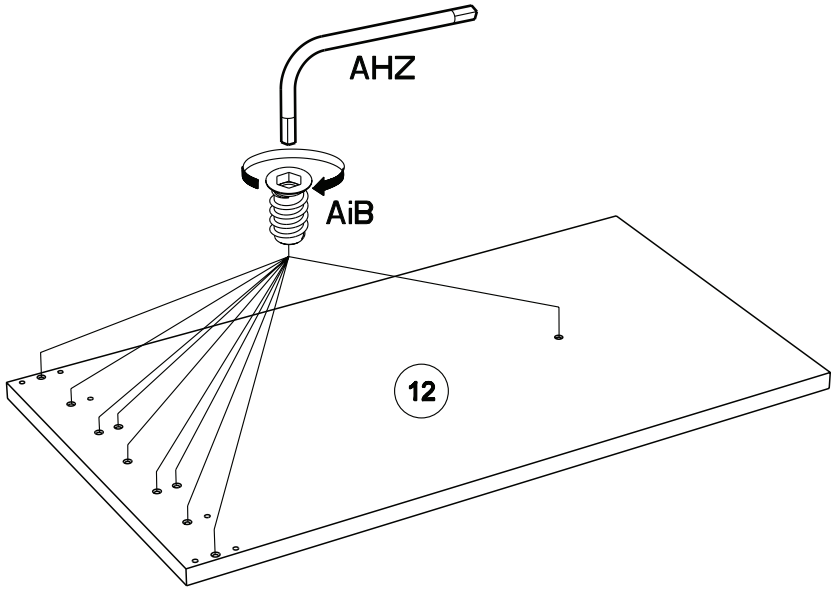
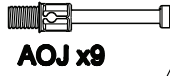
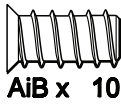

17



ADM x 15



CF x 1

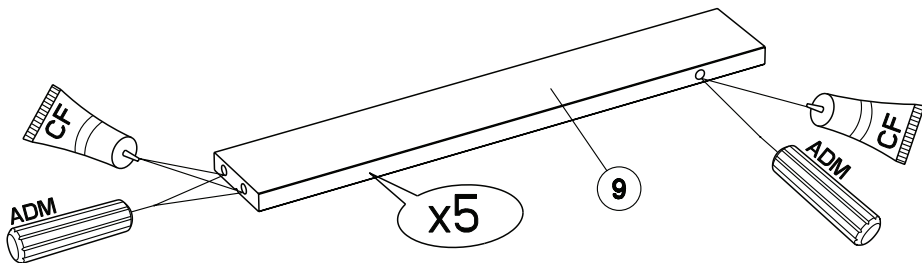

18



CF x 1

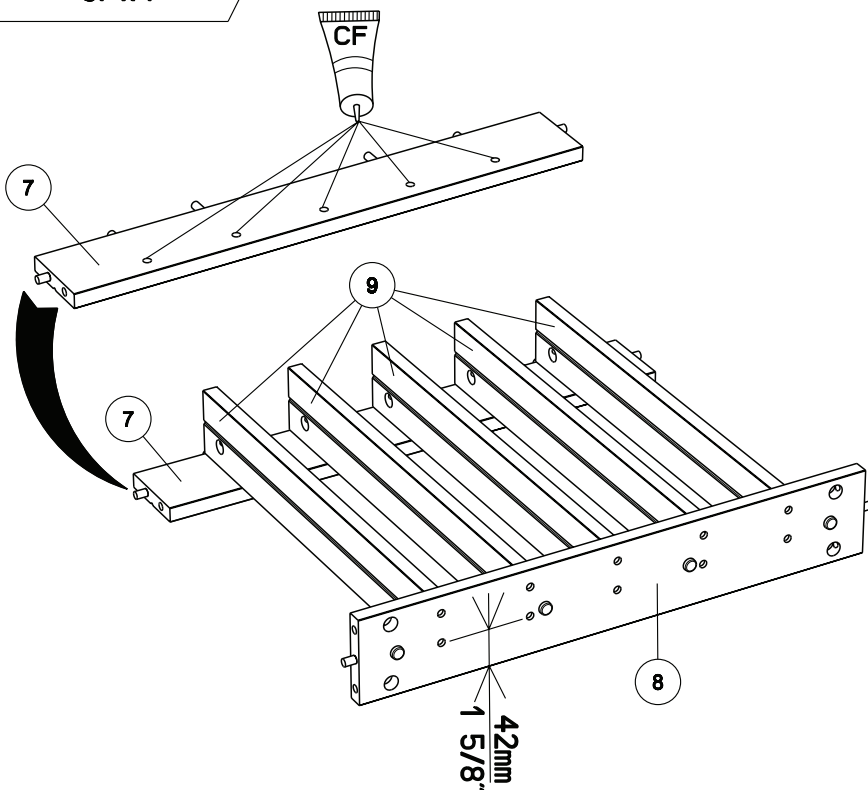

19



Ai x6

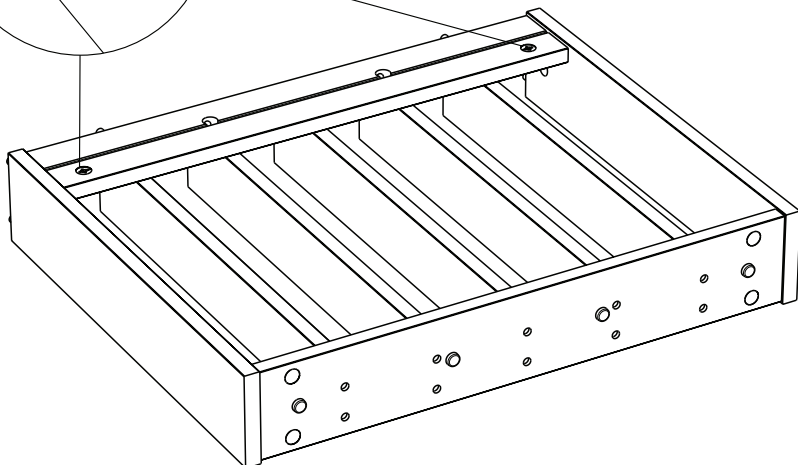
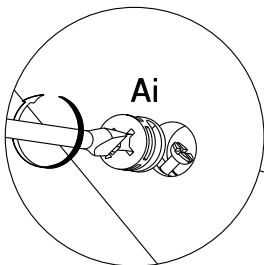
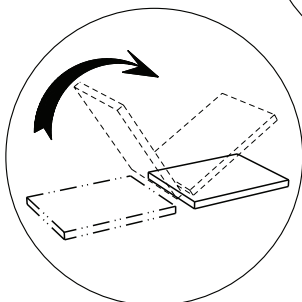
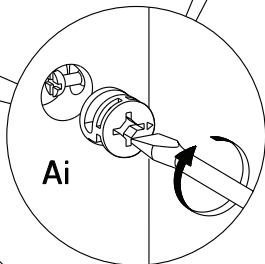
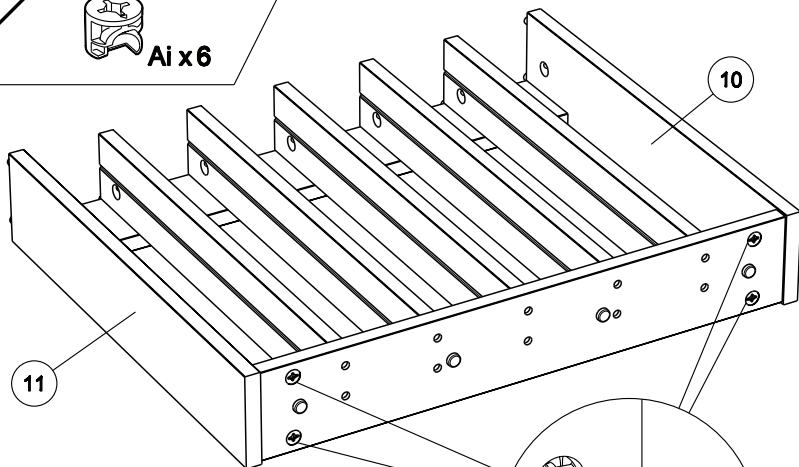

20



Ai x 2

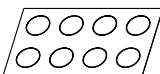

COL. x 1

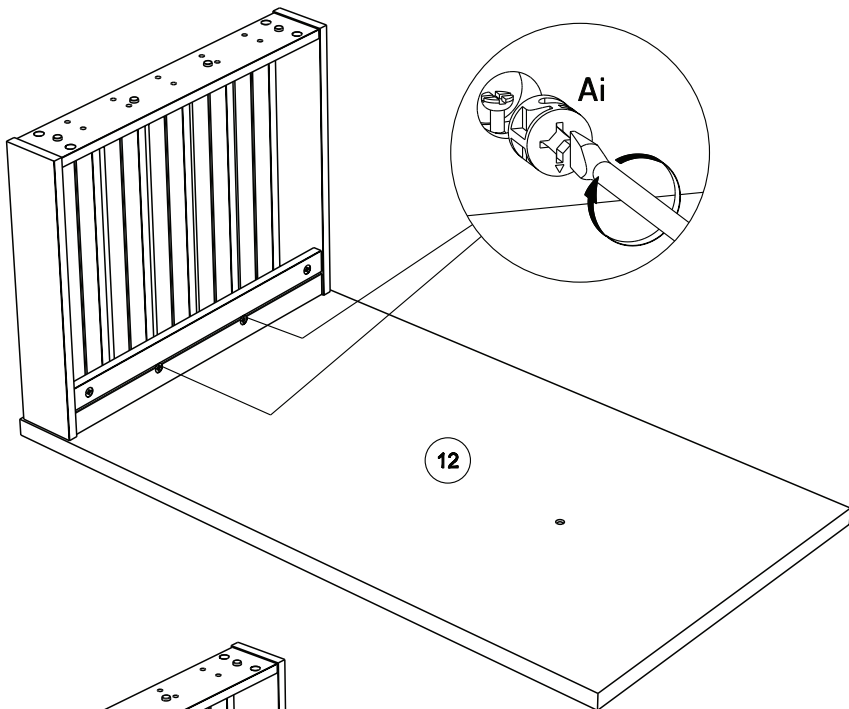

12

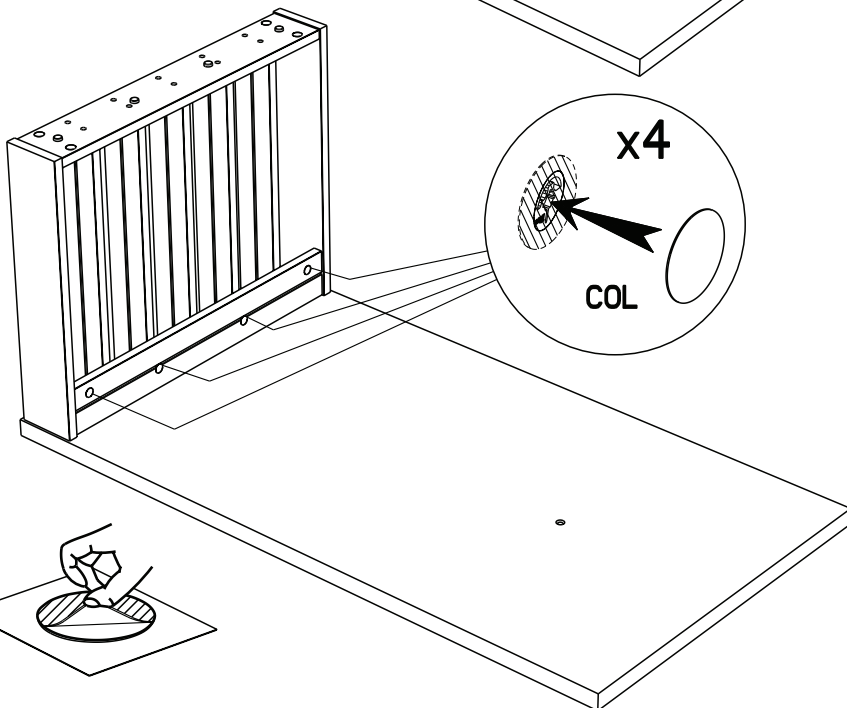

21



Ai x7



HV x1

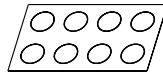

COL. x 1



CJX x1

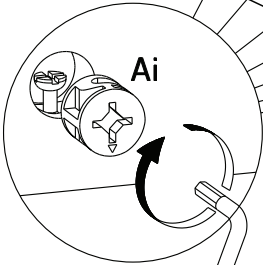
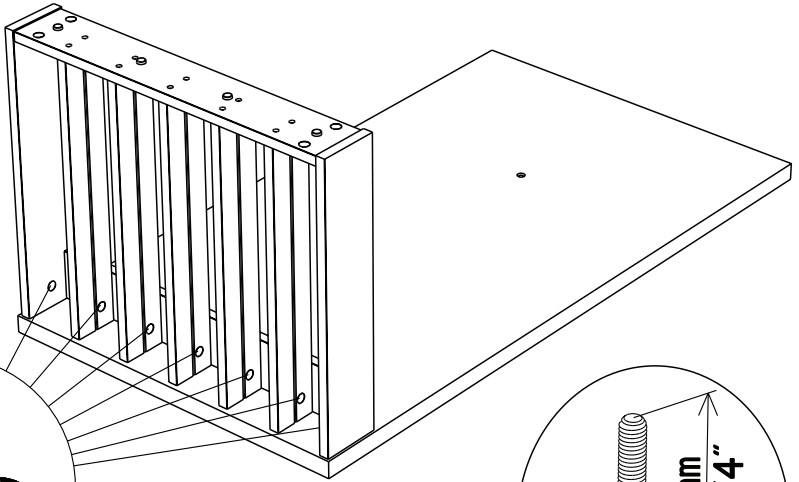

Ai

HV

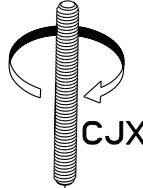

CJX

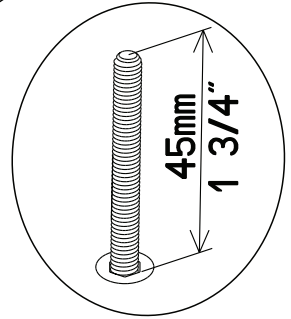

45mm
1 3/4"

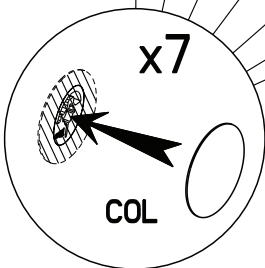
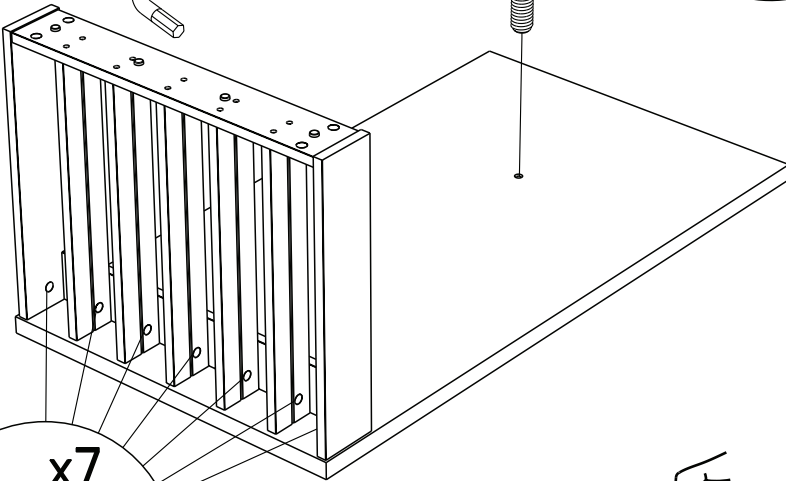

x7

COL

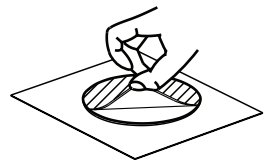

22



CHW x1

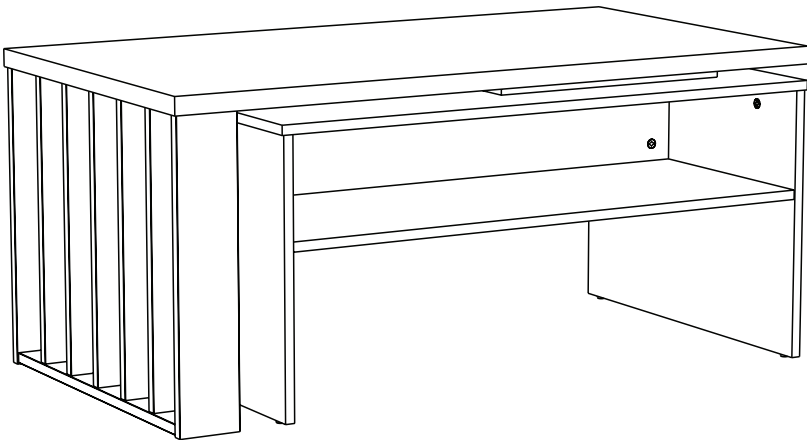
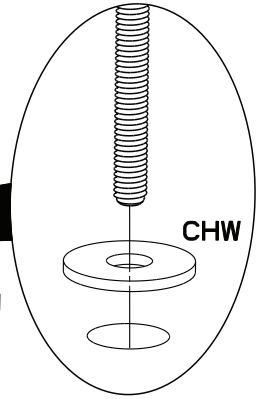
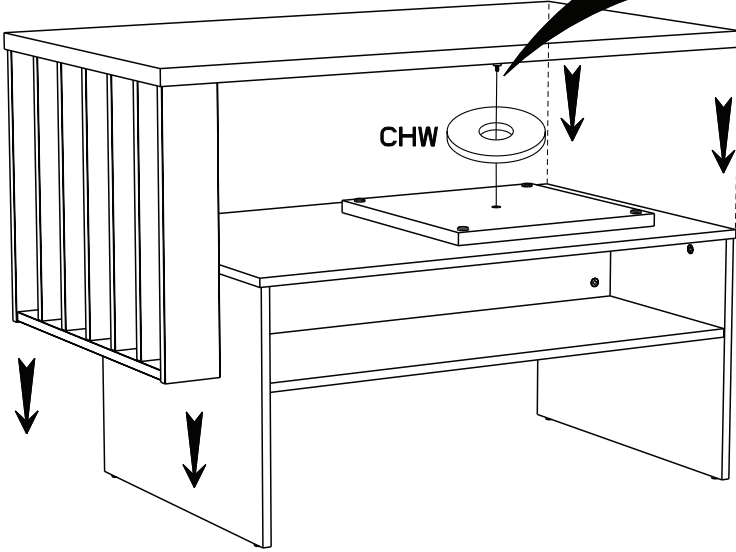

23

