

Beschläge sind in Colli C1.

① - C2	⑩ - C2, C3	⑳ - C5	③① - C6	③⑨ - C1	④⑨ - C4
② - C2, C3	⑪ - C2, C3	㉑ - C5	③② - C6	④① - C1	⑤① - C4
③ - C2, C3	⑫ - C2	㉒ - C6	③③ - C6	④② - C1	⑤② - C4
④ - C2	⑬ - C3	㉓ - C6	③④ - C5	④③ - C1	
⑤ - C2, C3	⑭ - C3	㉔ - C6	③⑤ - C5	④④ - C1	
⑥ - C2	⑮ - C3	㉕ - C6	③⑥ - C1	④⑤ - C1	
⑦ - C2	⑯ - C3	㉖ - C6	③⑦ - C1	④⑥ - C1	
⑧ - C2	⑰ - C3	㉗ - C5	③⑧ - C1	④⑦ - C4	
⑨a - C2, C3	⑱ - C3	㉘ - C6	③⑨ - C1	④⑧ - C4	
⑨b - C2, C3	⑲ - C5	㉙ - C6	③⑩ - C1	④⑨ - C4	

MONTAGEANLEITUNG / SERVICEKARTE

Montageanleitung sollte nicht als technische Dokumentation betrachtet werden. Aufbauänderungen vom Produzenten vorbehalten.

Sehr geehrter Kunde, sollte ein Teil fehlen oder beschädigt sein, kreuzen Sie bitte dieses deutlich auf der SERVICEKARD an und schicken Sie uns die SERVICEKARD zurück.

Den Kleber benutzen Sie nur zum Verleimen der Schubladen.

Um die eventuellen Reklas richtig zu erledigen, bitten wir um eine Kopie des Aufklebers von der Ware, oder um Angabe der Produktionswoche.

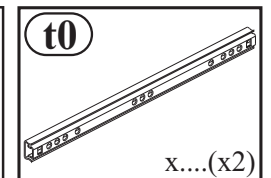
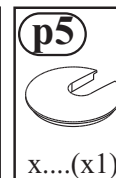
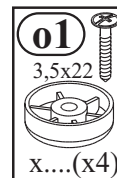
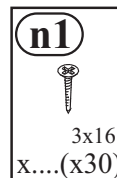
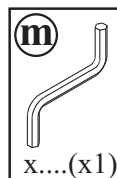
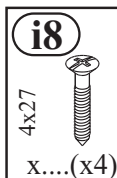
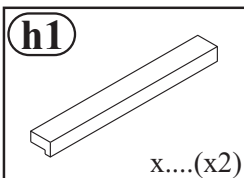
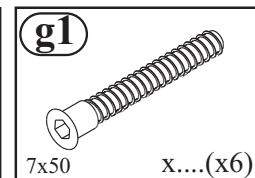
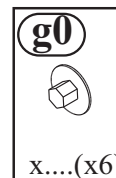
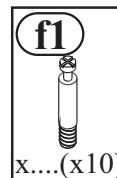
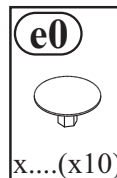
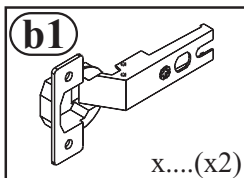
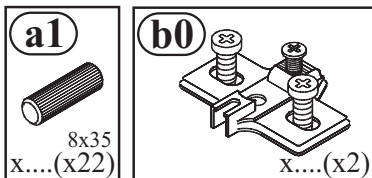
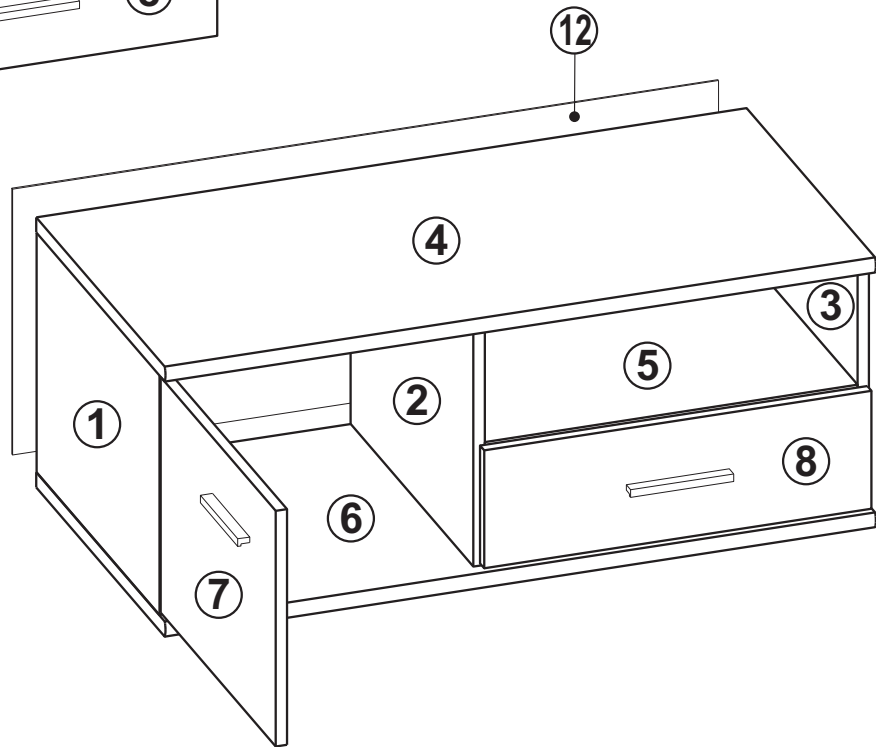
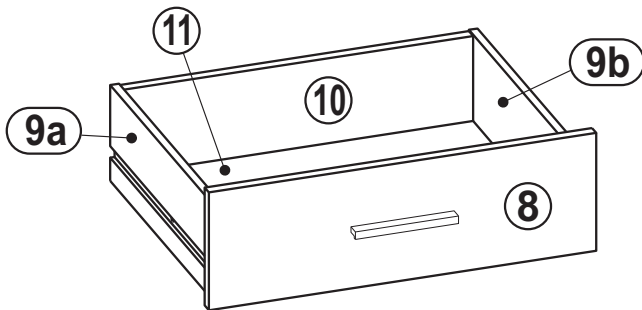
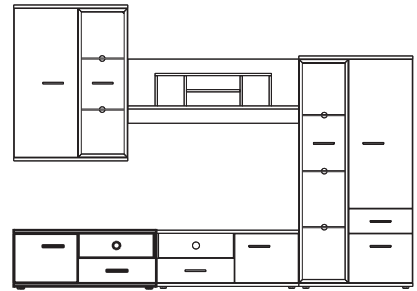

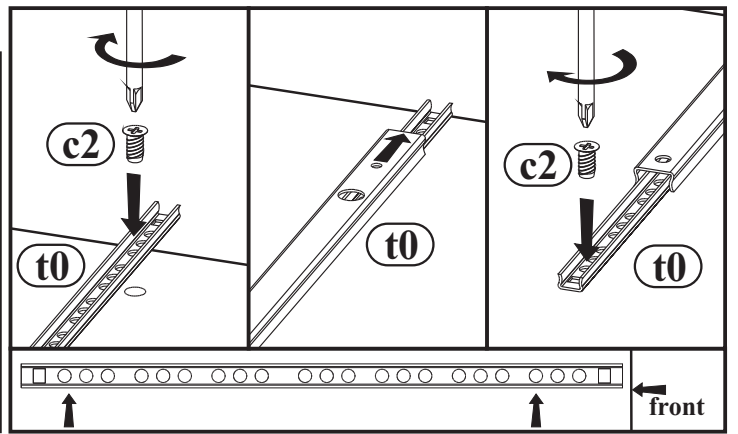
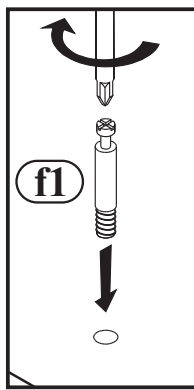
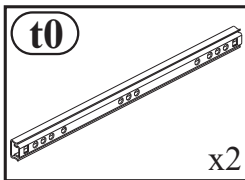
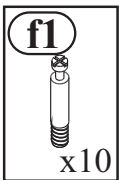
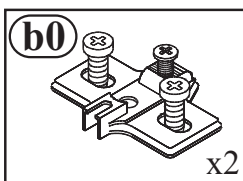
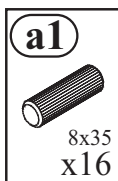
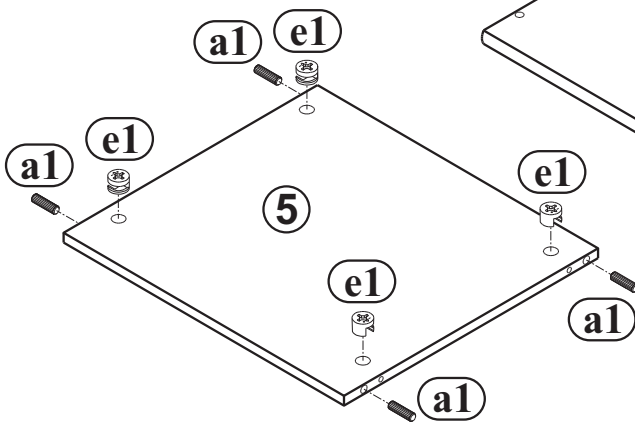
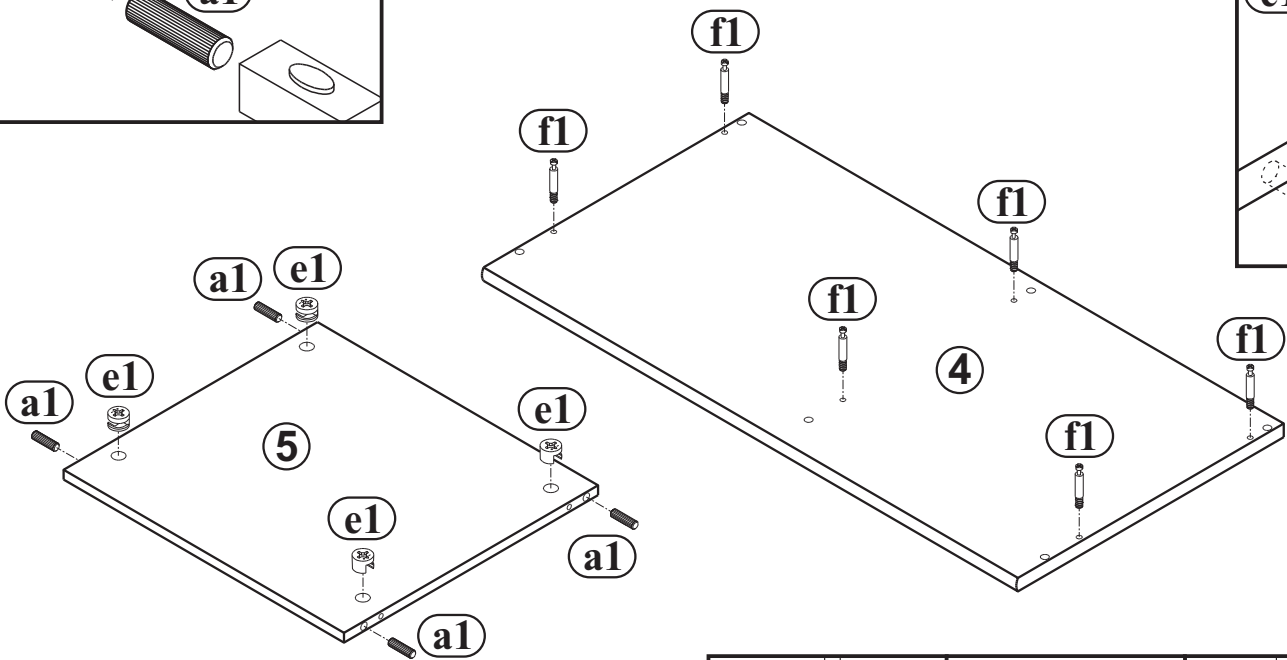
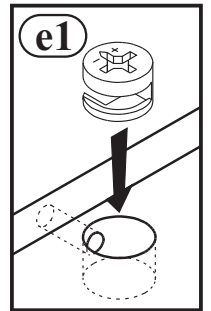
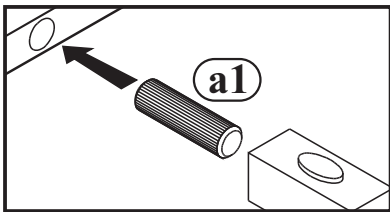
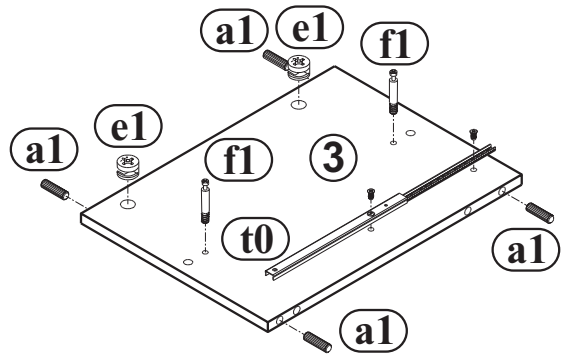
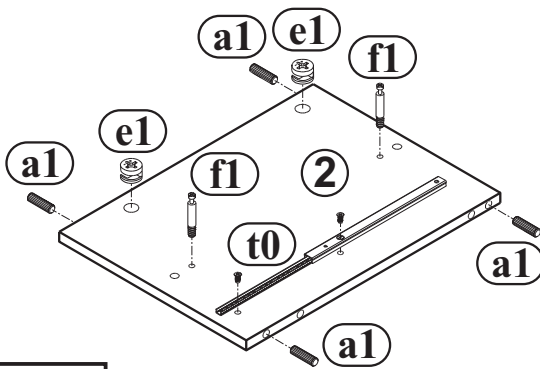
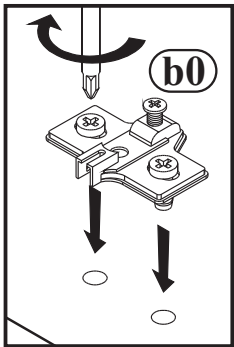
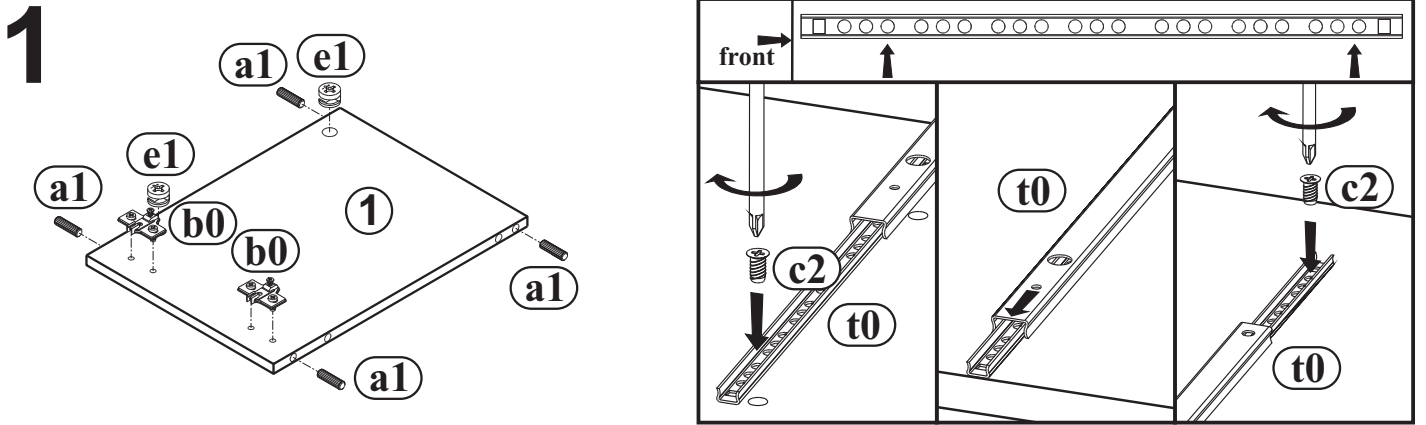

5

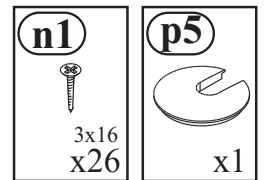
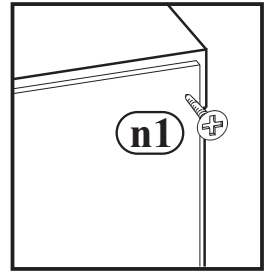
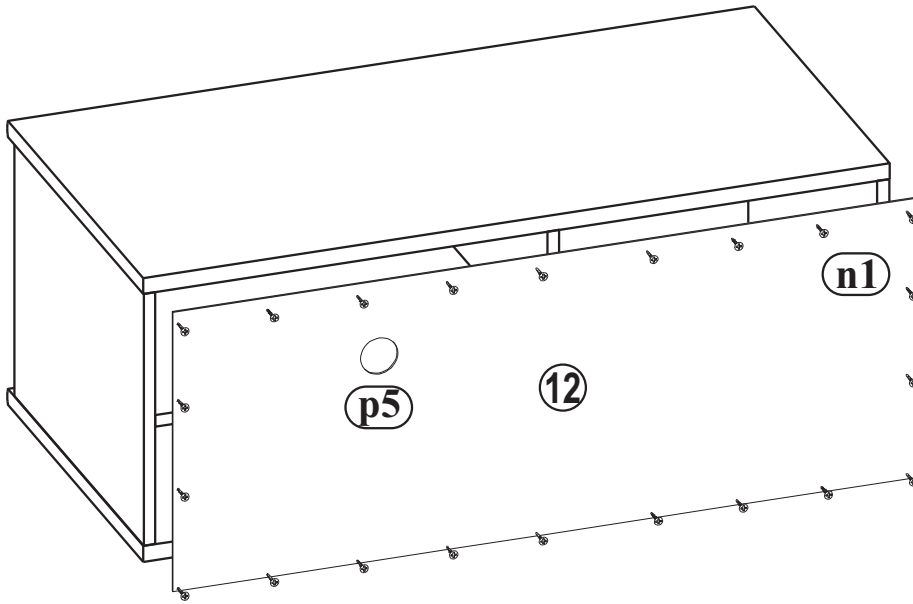

6

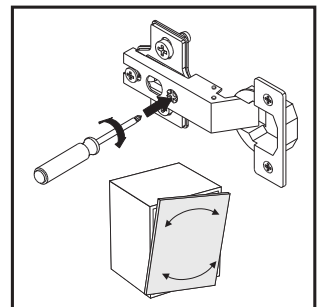
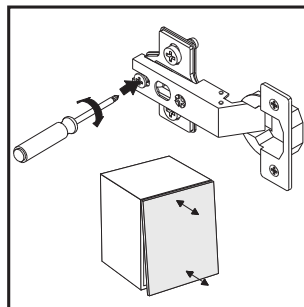
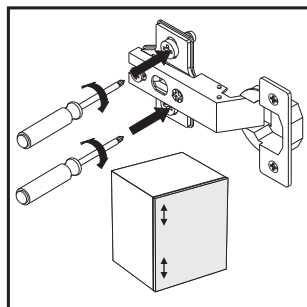
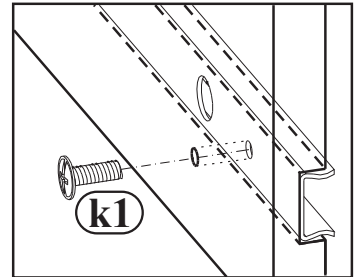
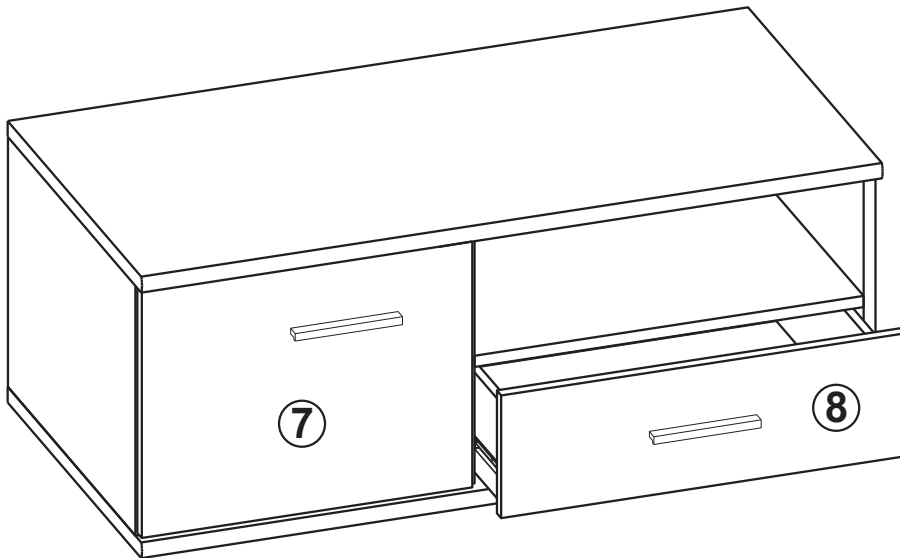

MONTAGEANLEITUNG / SERVICEKARTE

Montageanleitung sollte nicht als technische Dokumentation betrachtet werden. Aufbauänderungen vom Produzenten vorbehalten.

Sehr geehrter Kunde, sollte ein Teil fehlen oder beschädigt sein, kreuzen Sie bitte dieses deutlich auf der SERVICEKARD an und schicken Sie uns die SERVICEKARD zurück.

Den Kleber benutzen Sie nur zum Verleimen der Schubladen.

Um die eventuellen Reklas richtig zu erledigen, bitten wir um eine Kopie des Aufklebers von der Ware, oder um Angabe der Produktionswoche.

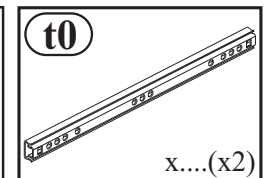
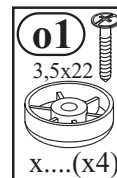
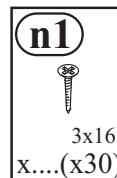
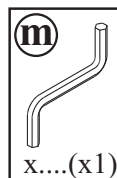
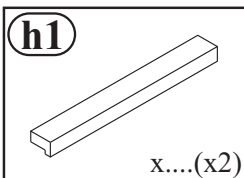
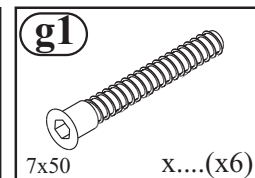
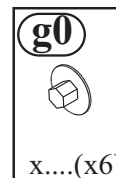
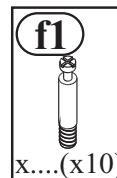
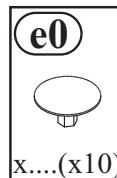
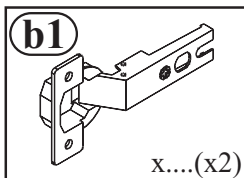
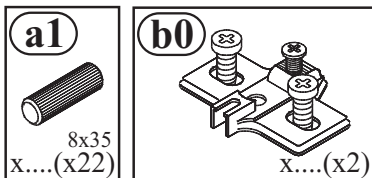
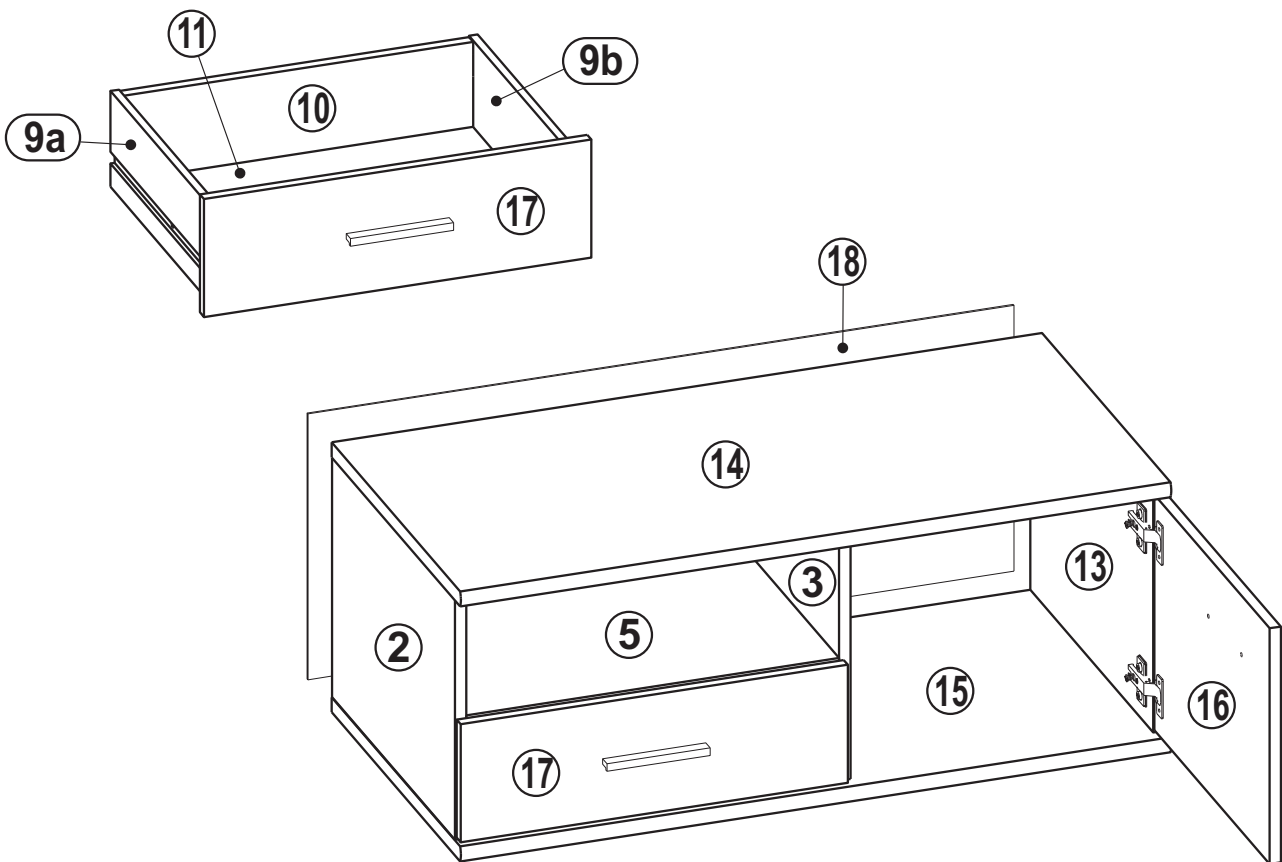
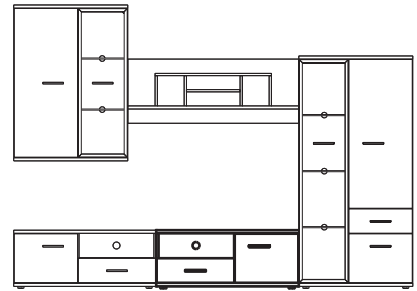

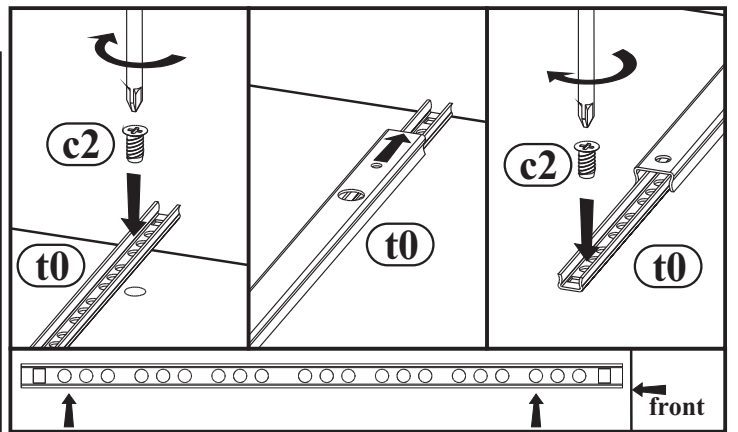
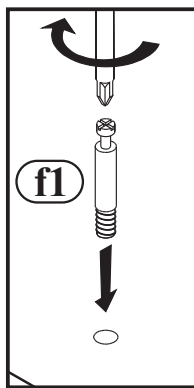
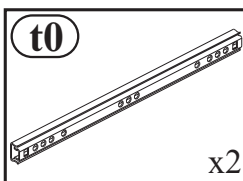
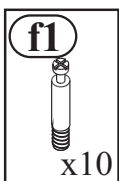
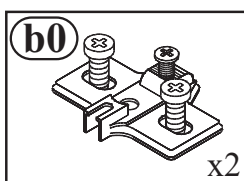
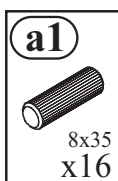
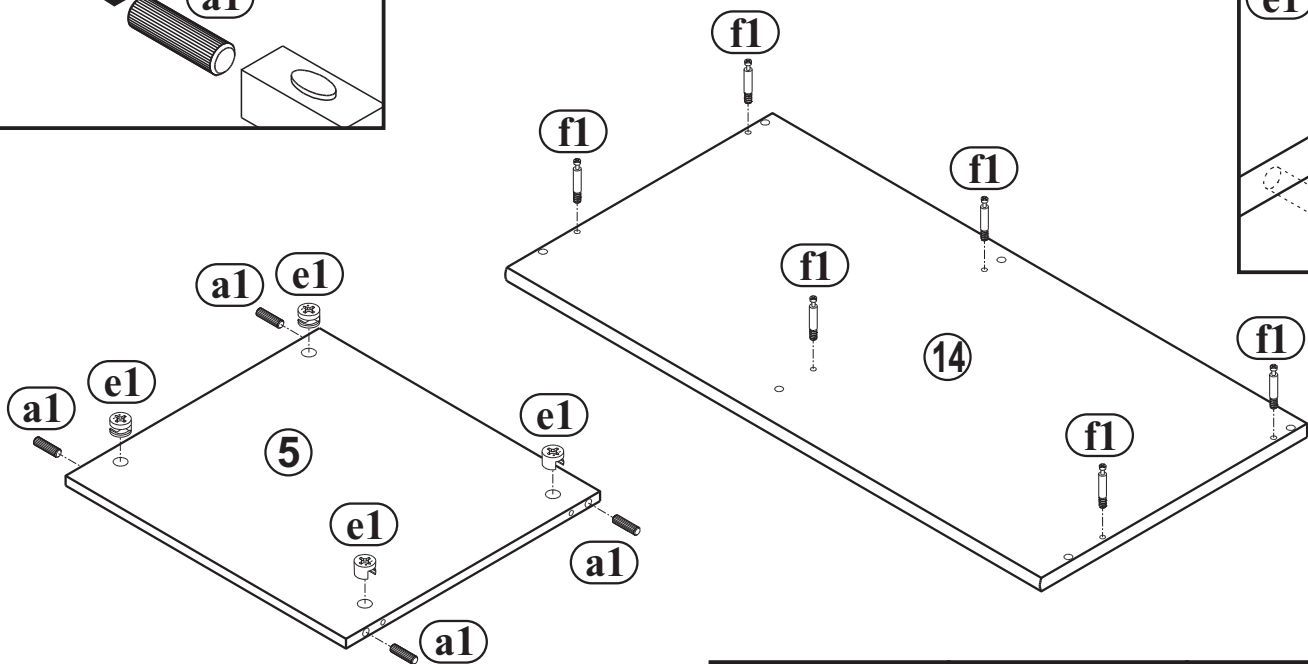
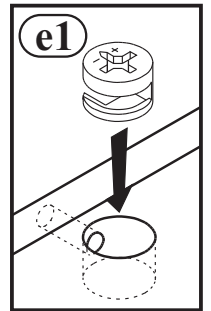
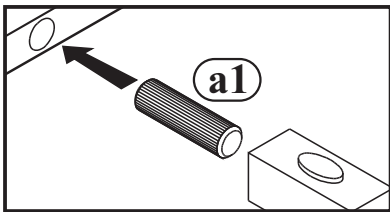
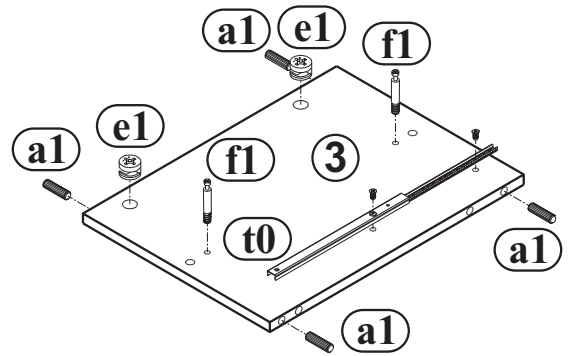
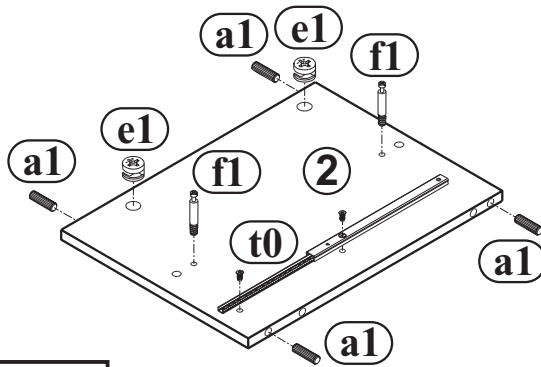
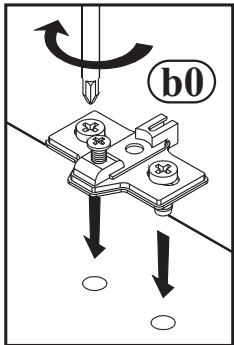
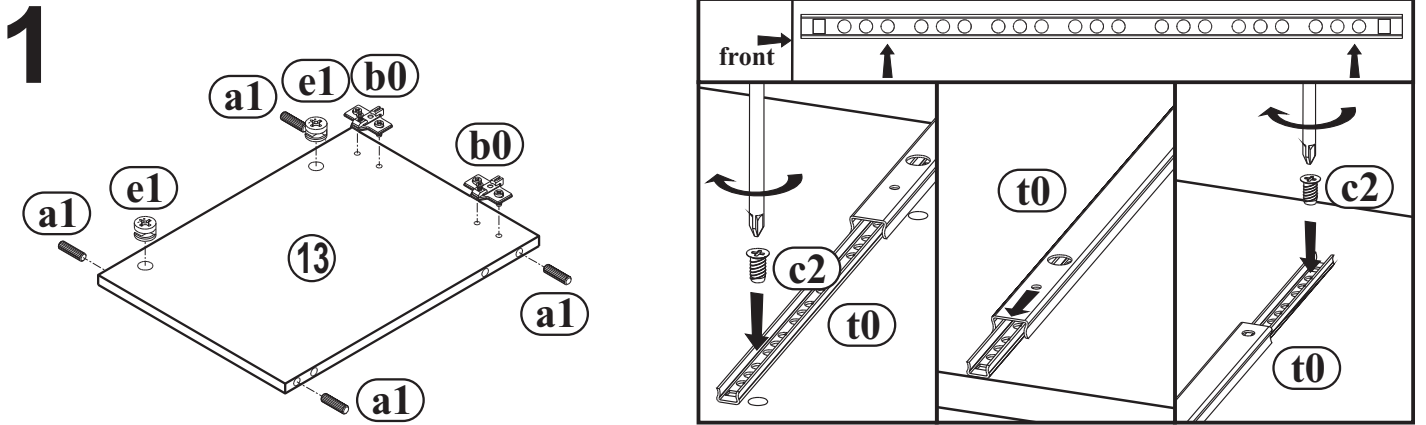

2

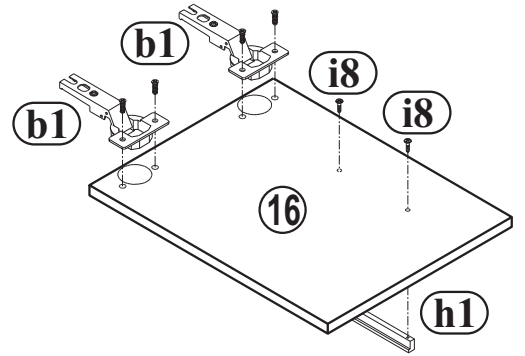
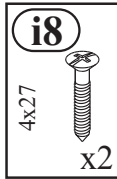
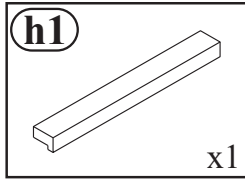
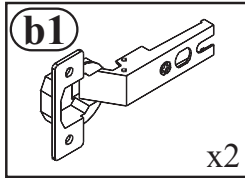
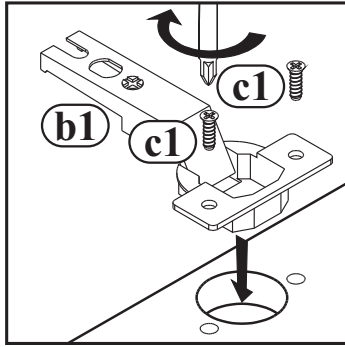

3

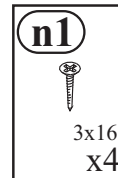
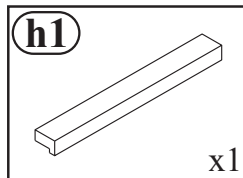
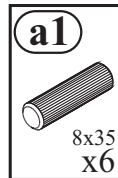
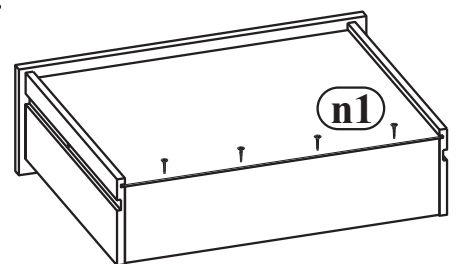
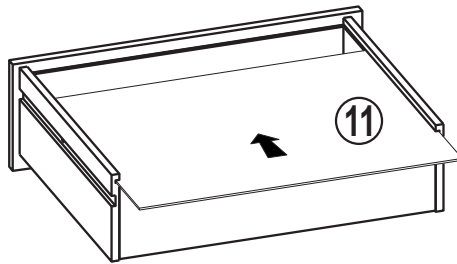
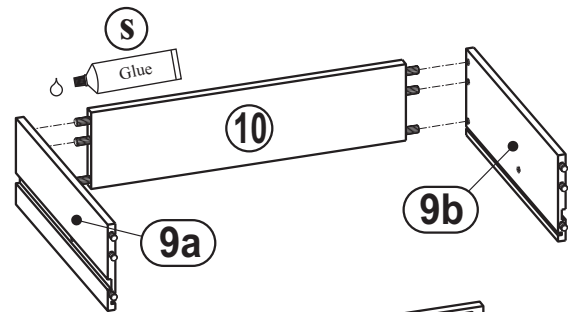
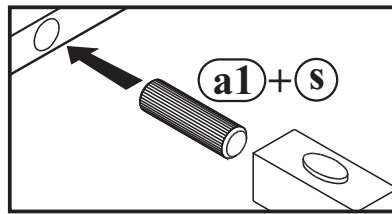
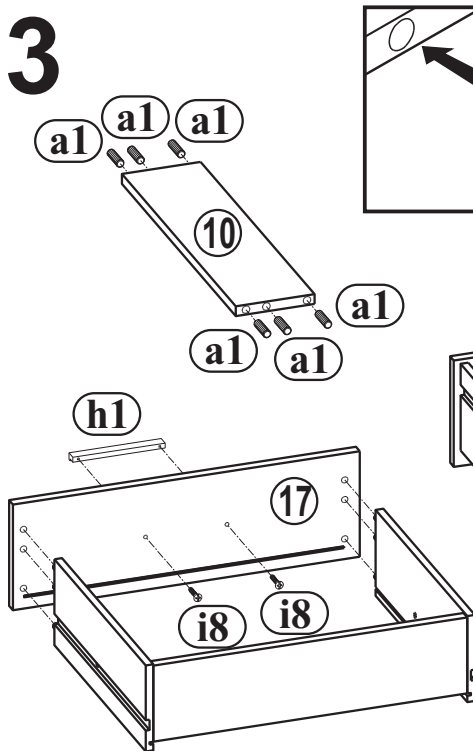

4

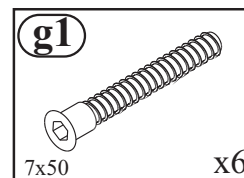
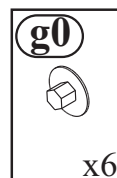
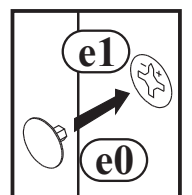
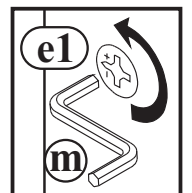
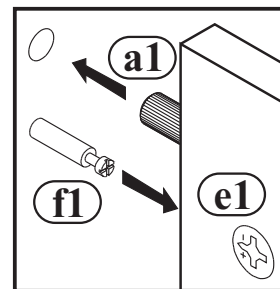
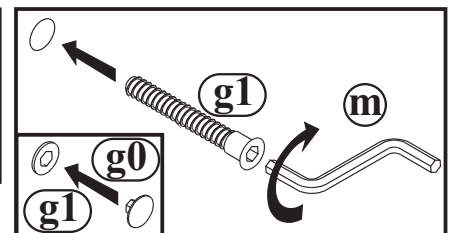
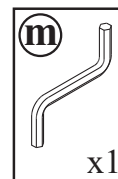
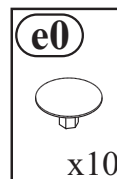
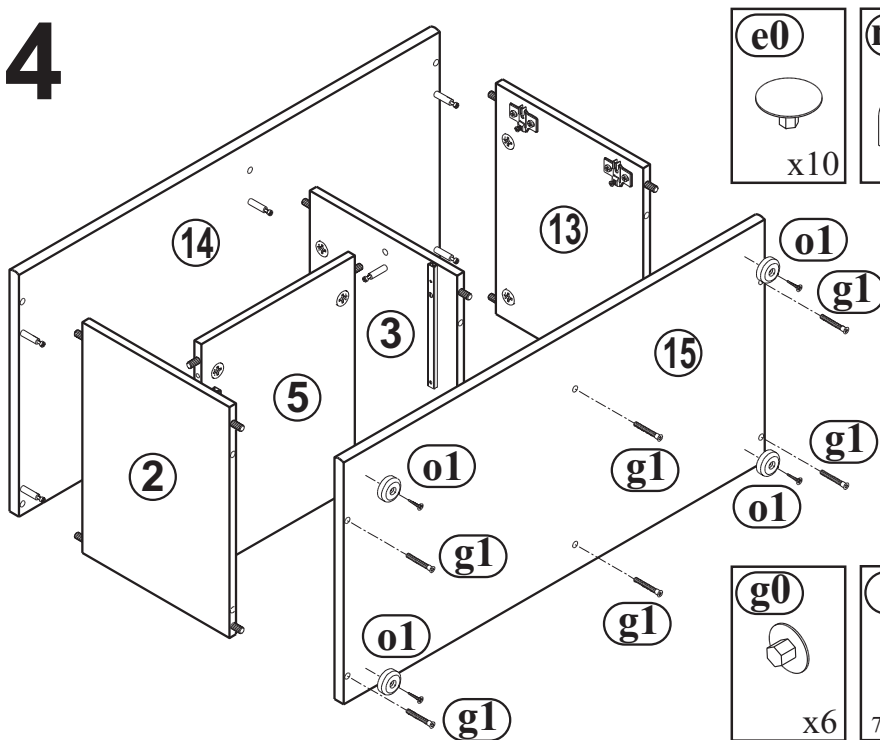

5

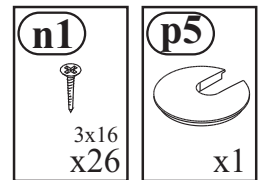
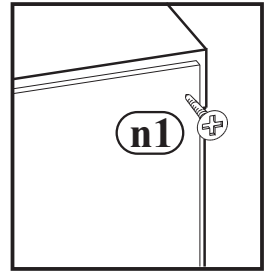
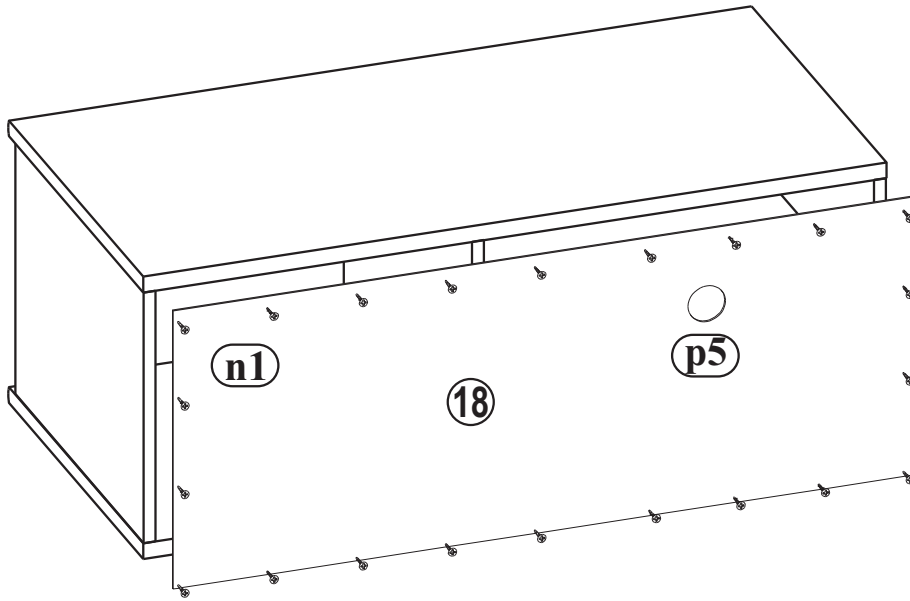

6

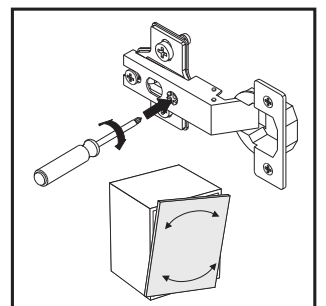
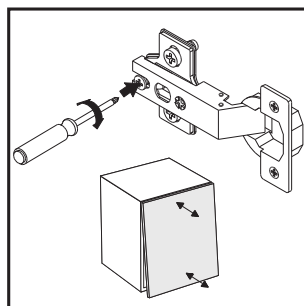
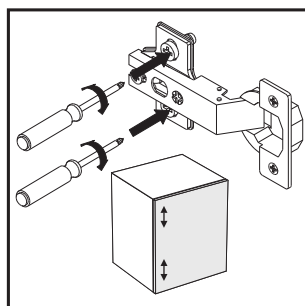
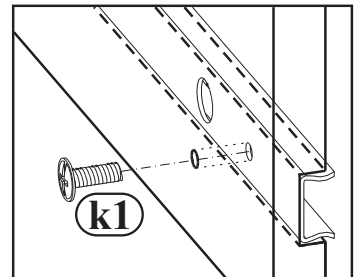
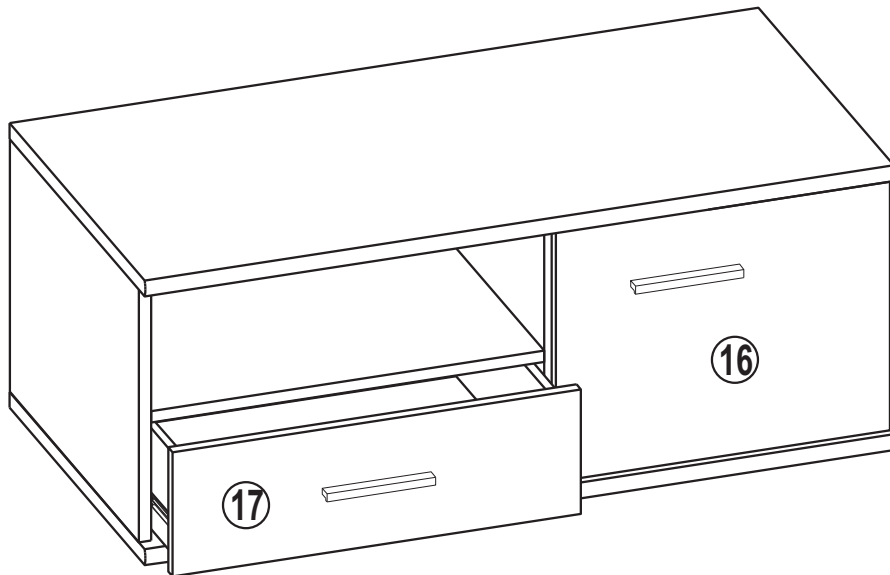

MONTAGEANLEITUNG / SERVICEKARTE

Montageanleitung sollte nicht als technische Dokumentation betrachtet werden. Aufbauänderungen vom Produzenten vorbehalten.

Sehr geehrter Kunde, sollte ein Teil fehlen oder beschädigt sein, kreuzen Sie bitte dieses deutlich auf der SERVICEKARD an und schicken Sie uns die SERVICEKARD zurück.

Den Kleber benutzen Sie nur zum Verleimen der Schubladen.

Um die eventuellen Reklas richtig zu erledigen, bitten wir um eine Kopie des Aufklebers von der Ware, oder um Angabe der Produktionswoche.

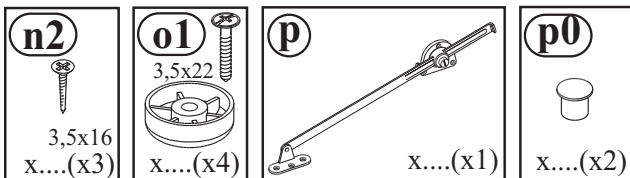
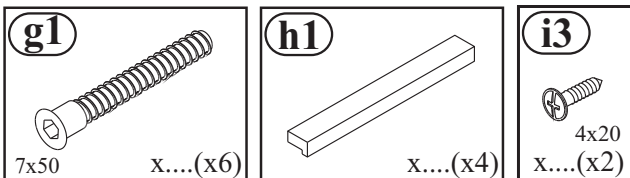
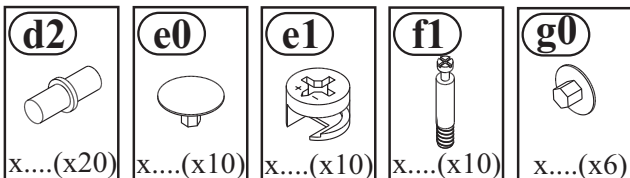
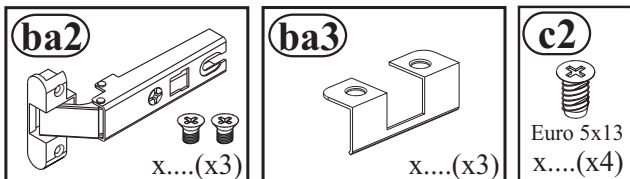
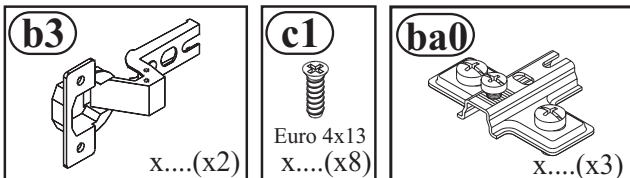
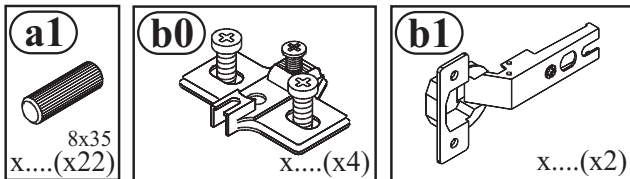
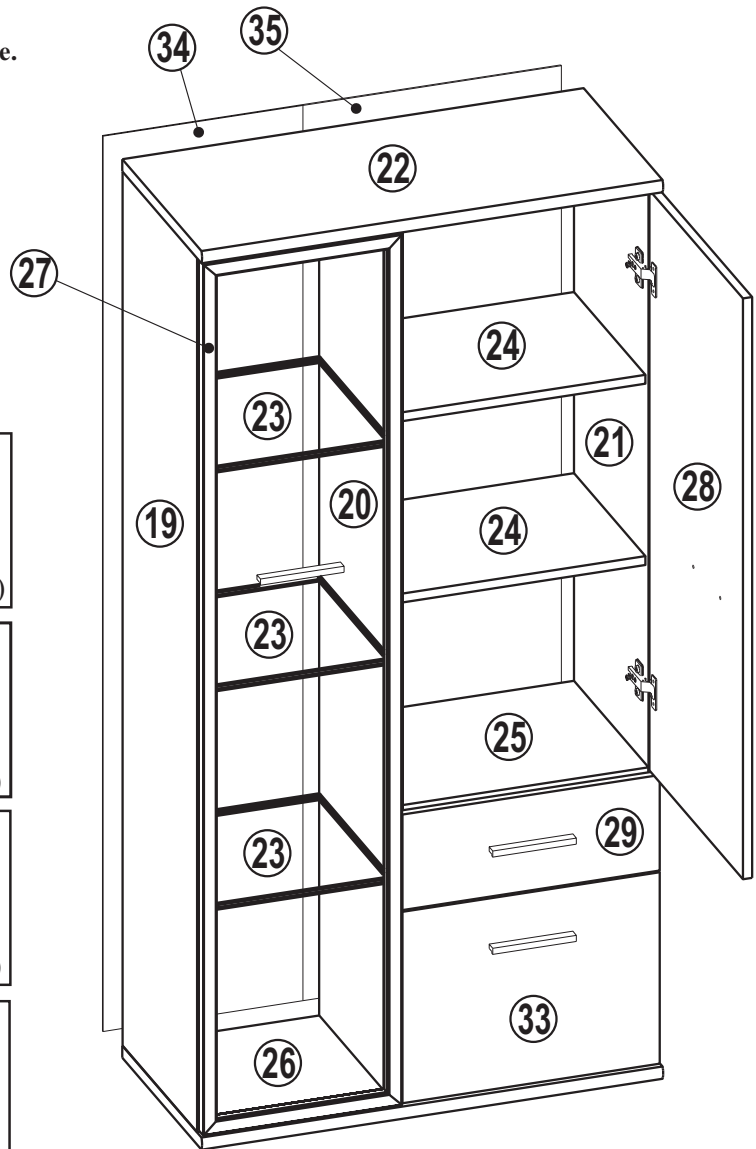
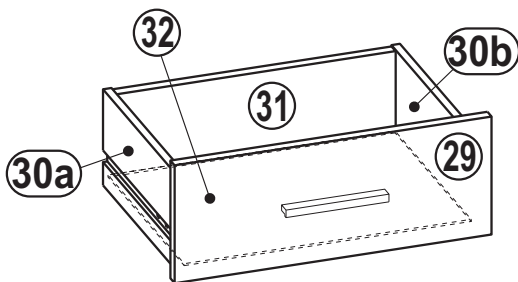
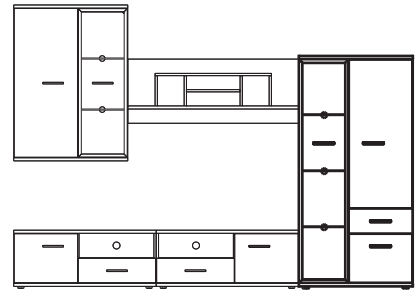

1

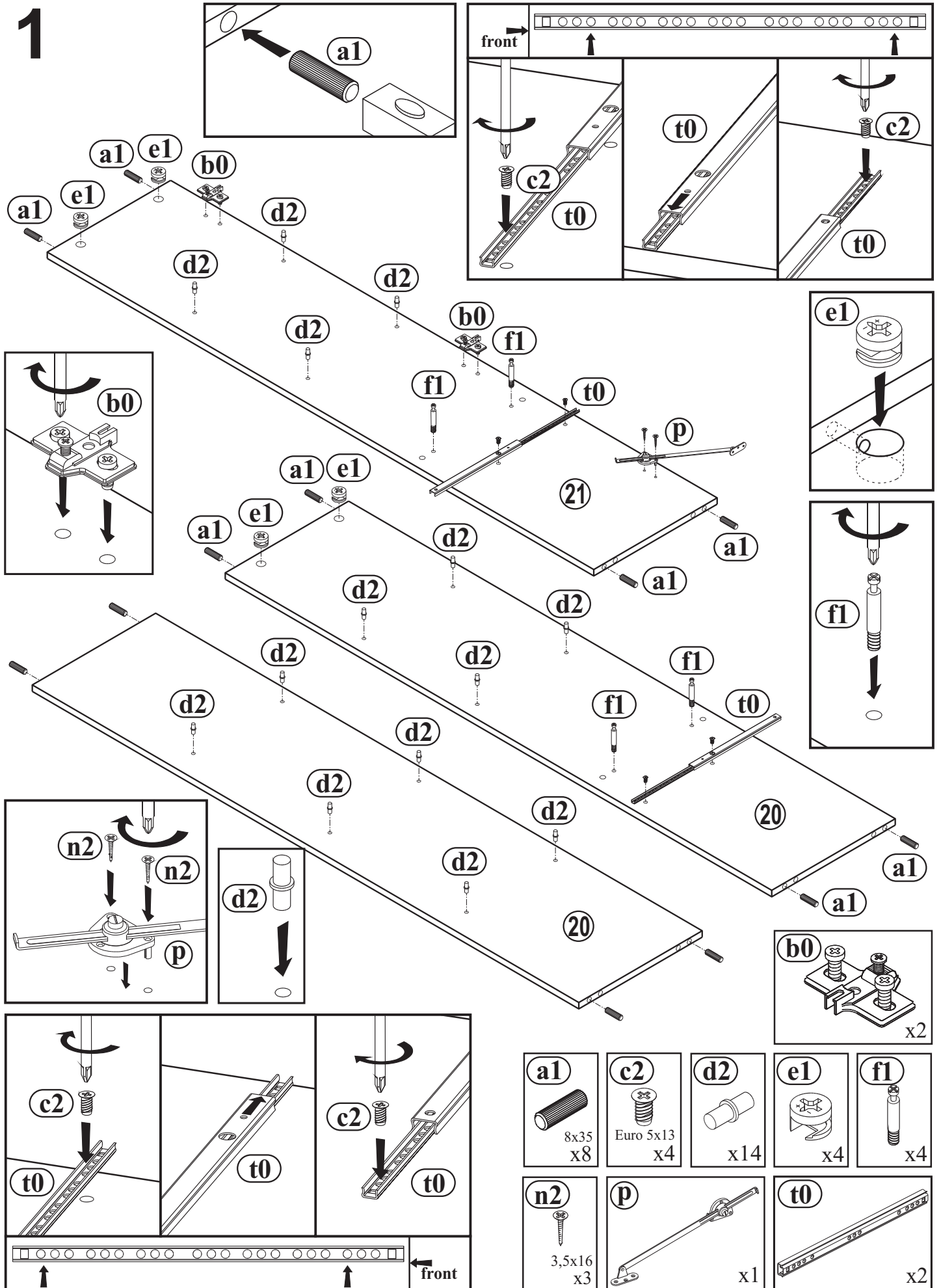

a1 8x35 x8	c2 Euro 5x13 x4	d2 x14	e1 x4	f1 x4
n2 3,5x16 x3	p x1	t0 x2		

2

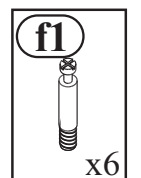
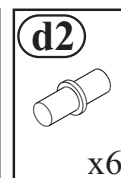
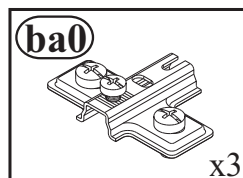
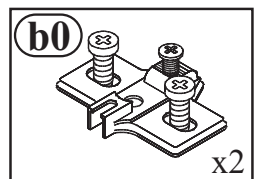
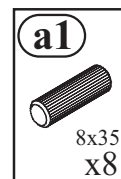
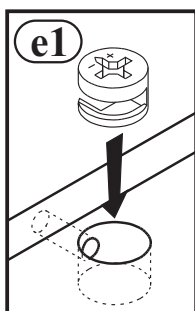
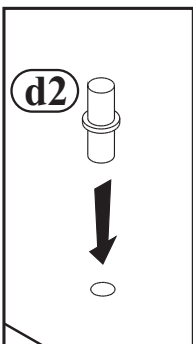
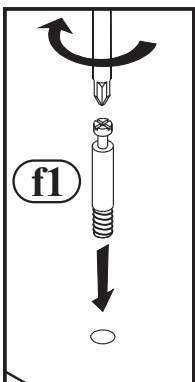
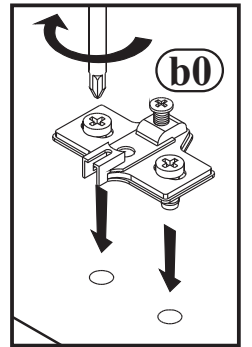
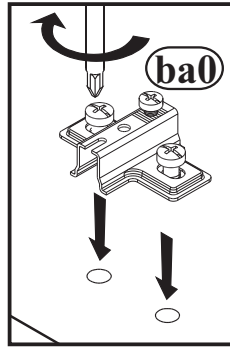
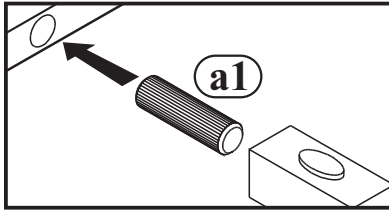
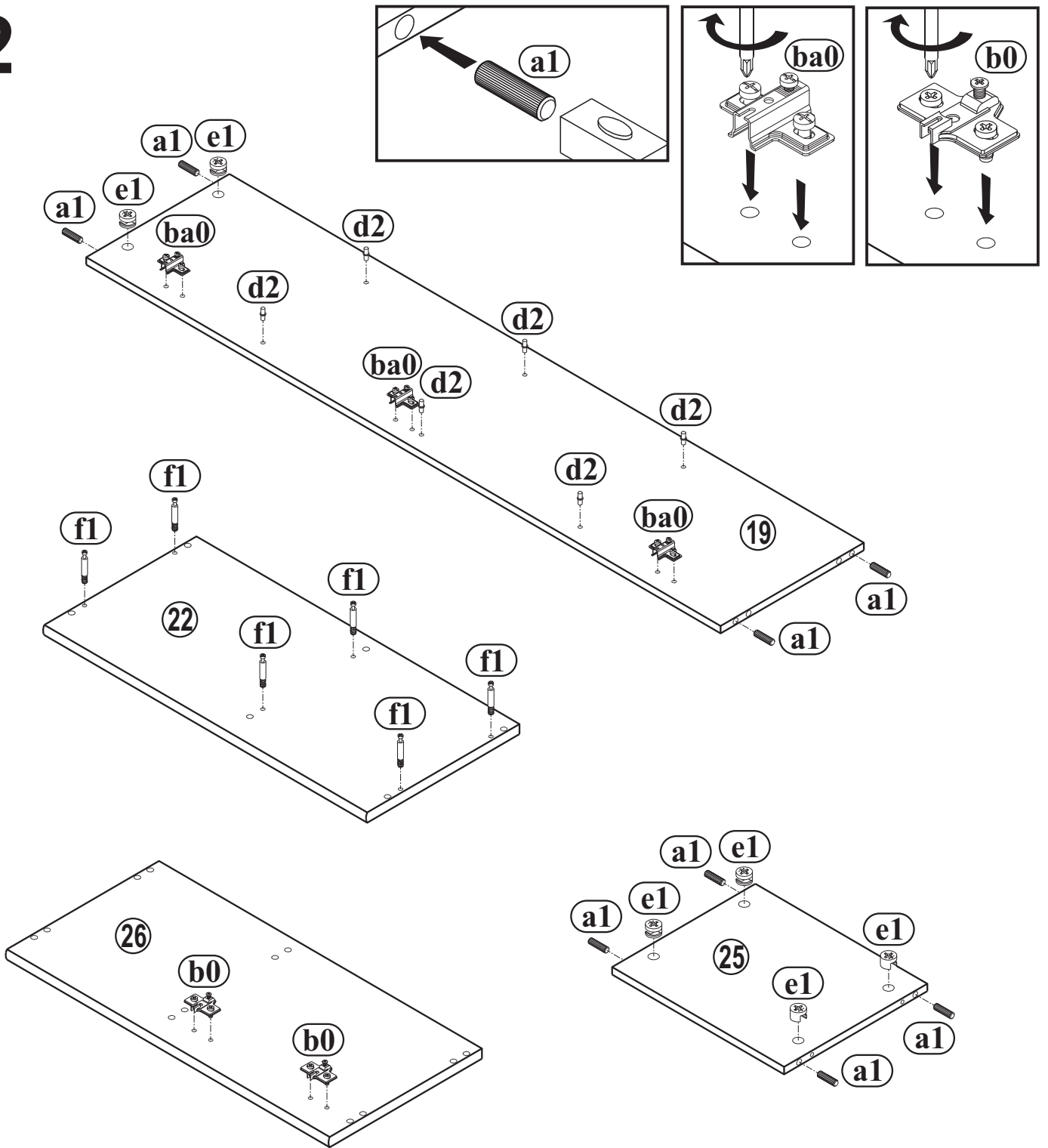

3

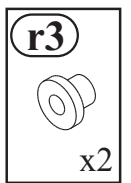
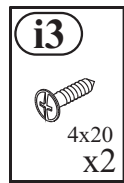
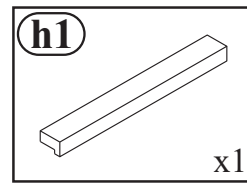
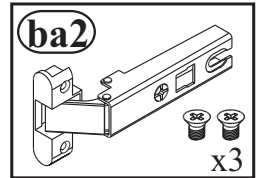
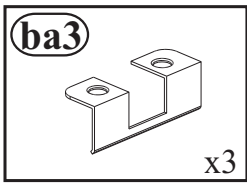
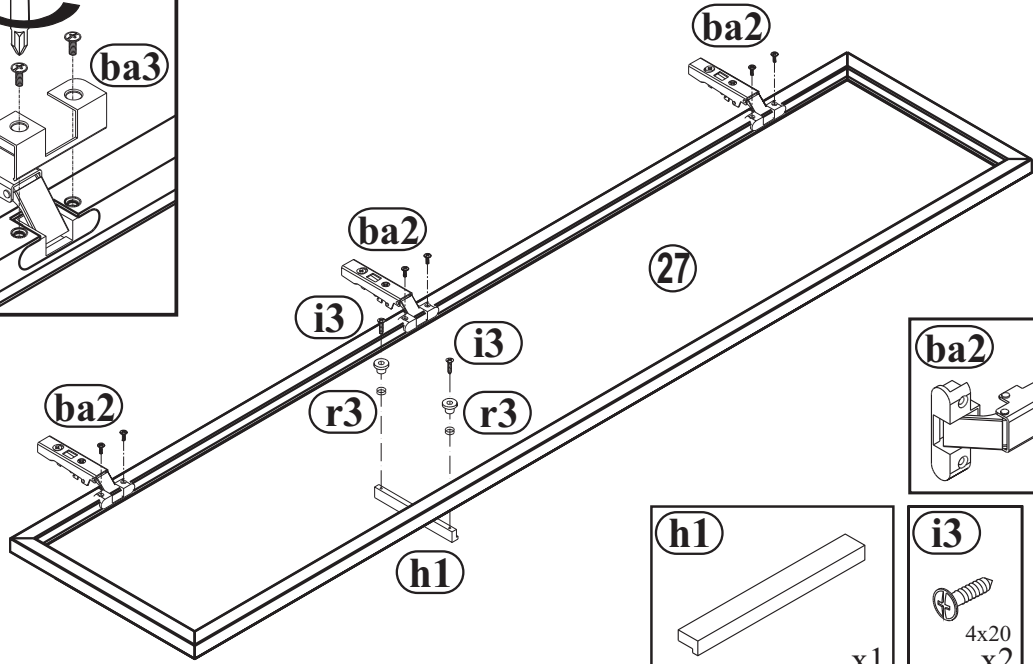
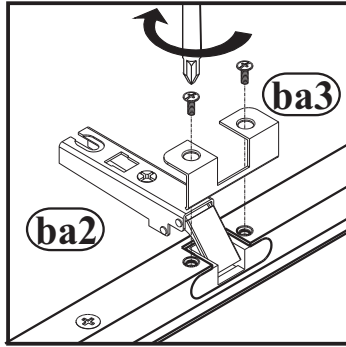

4

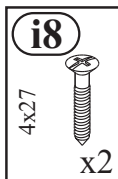
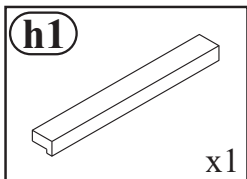
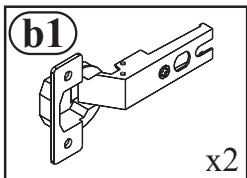
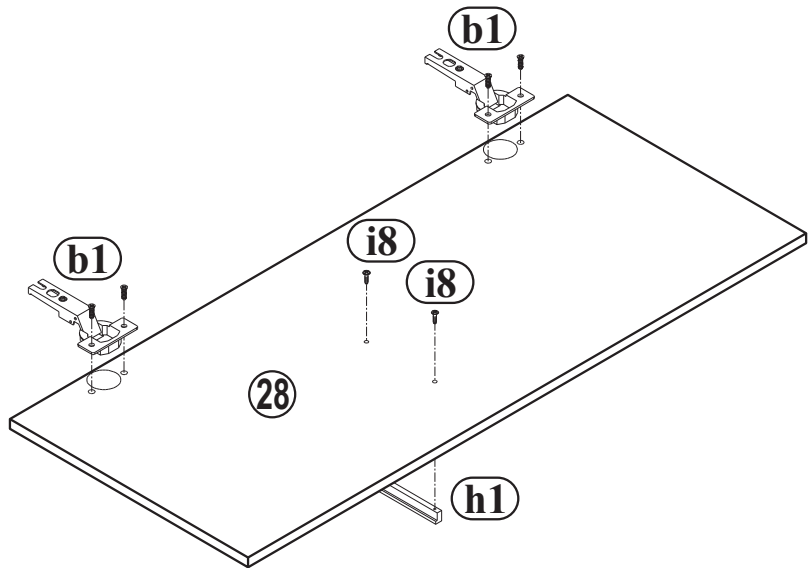
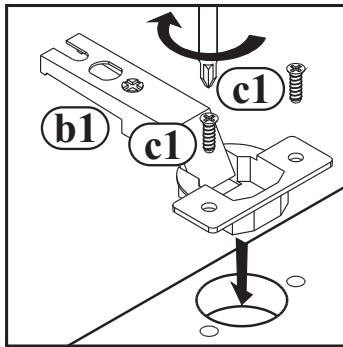

5

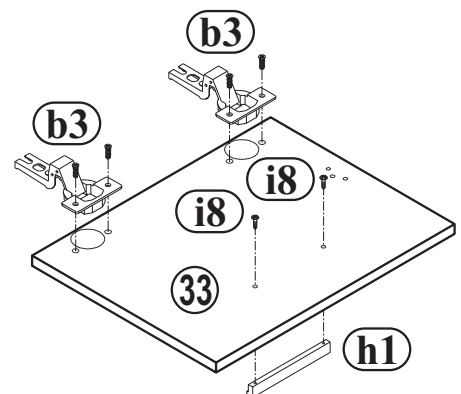
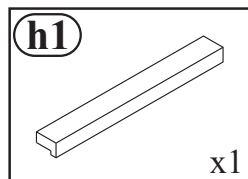
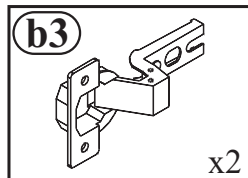
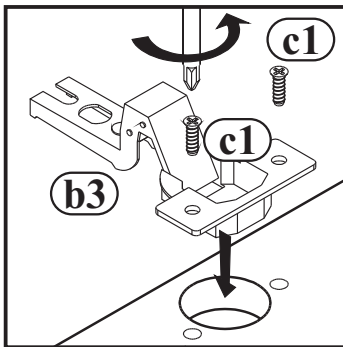

6

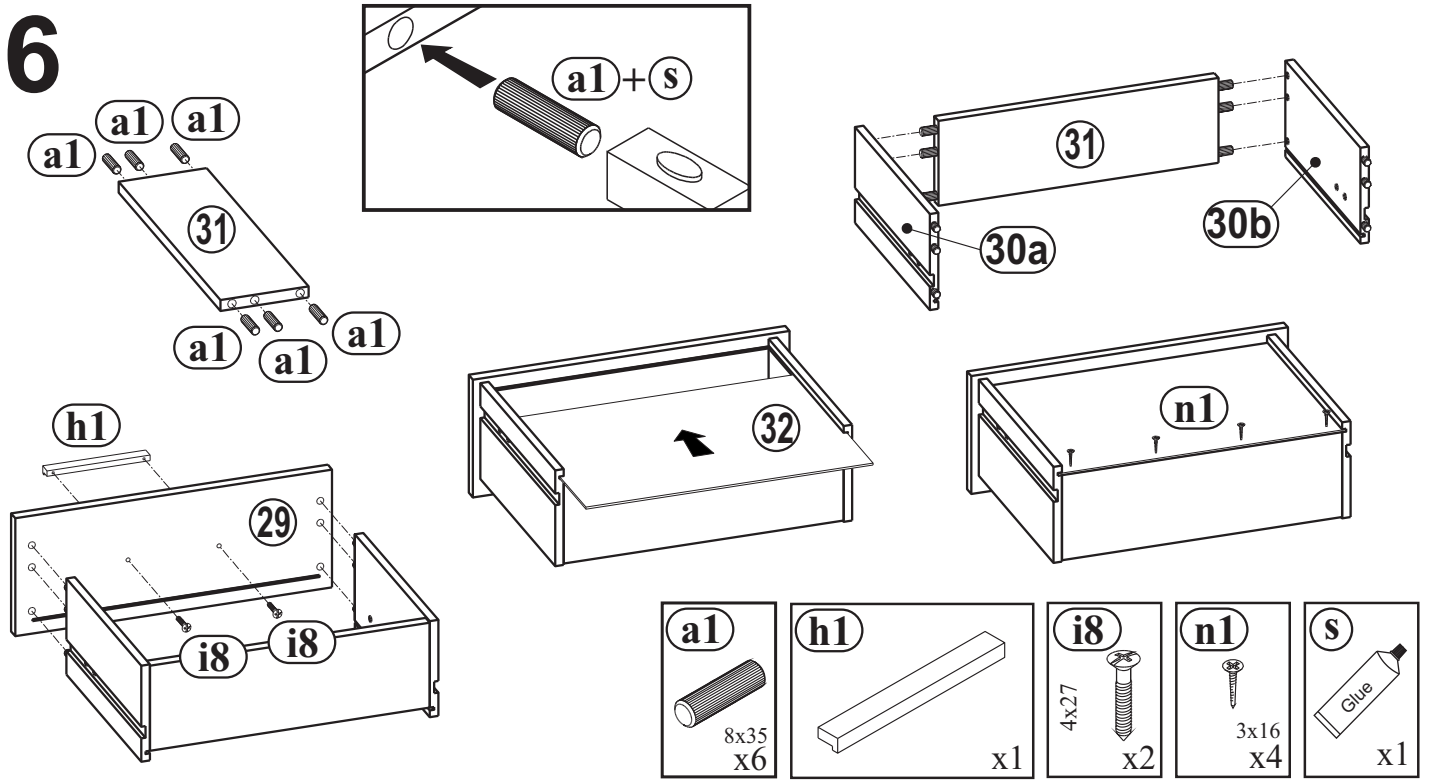

7

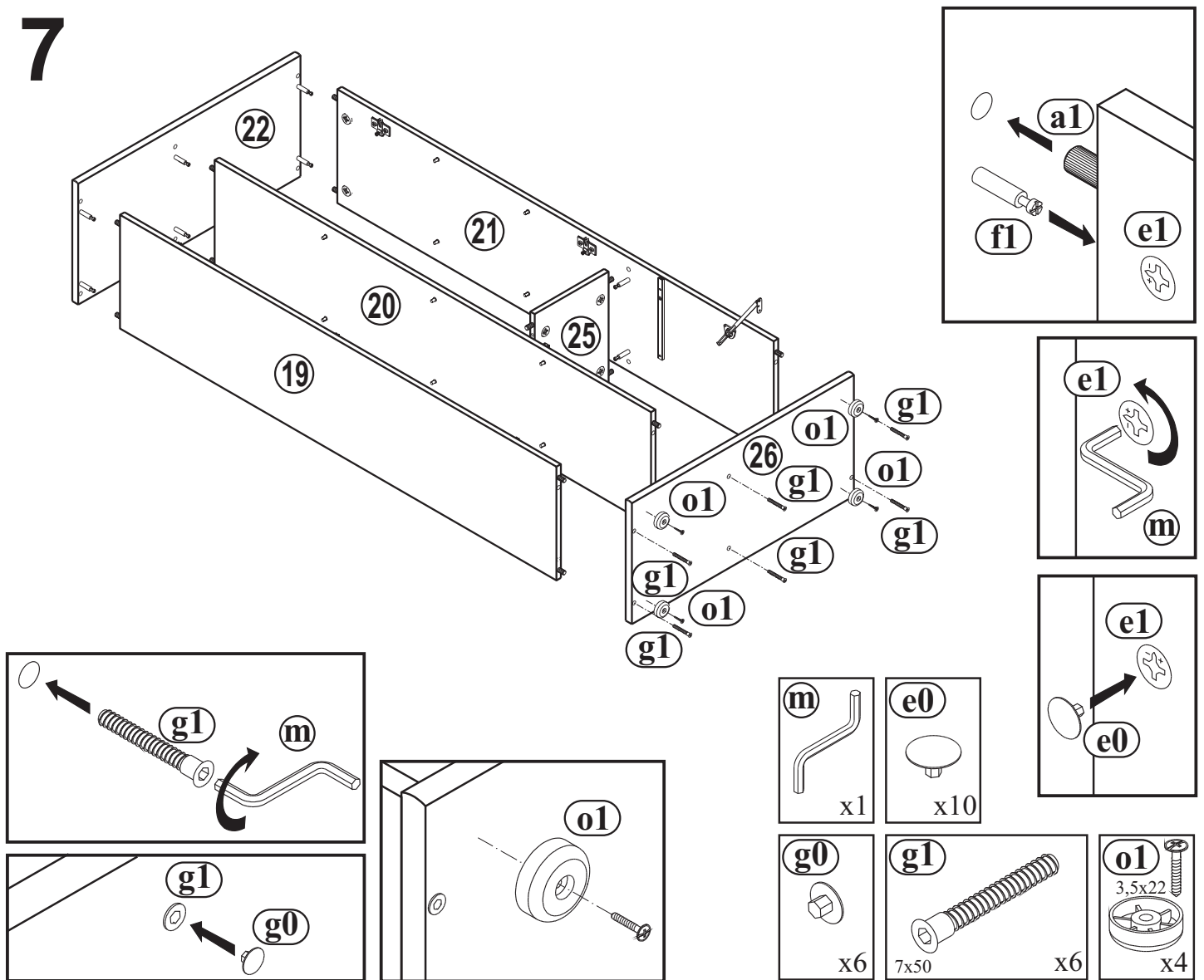

8

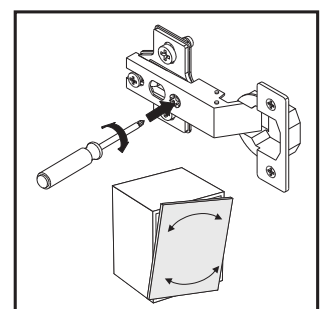
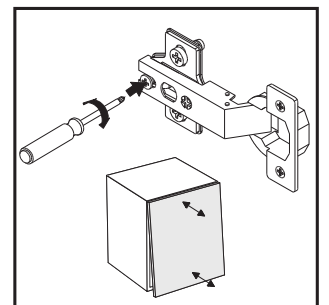
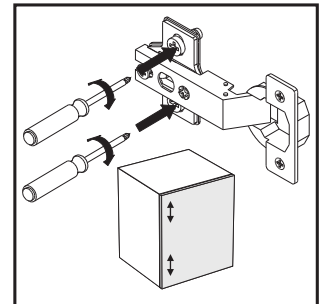
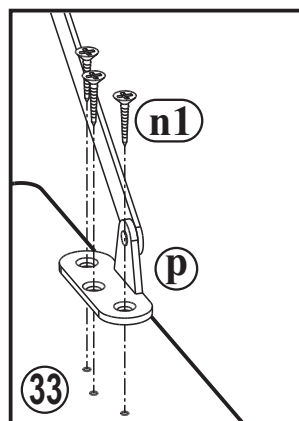
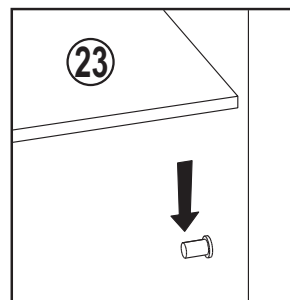
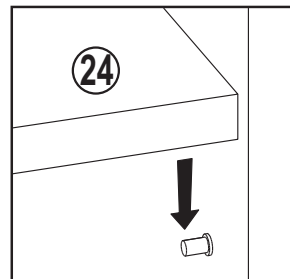
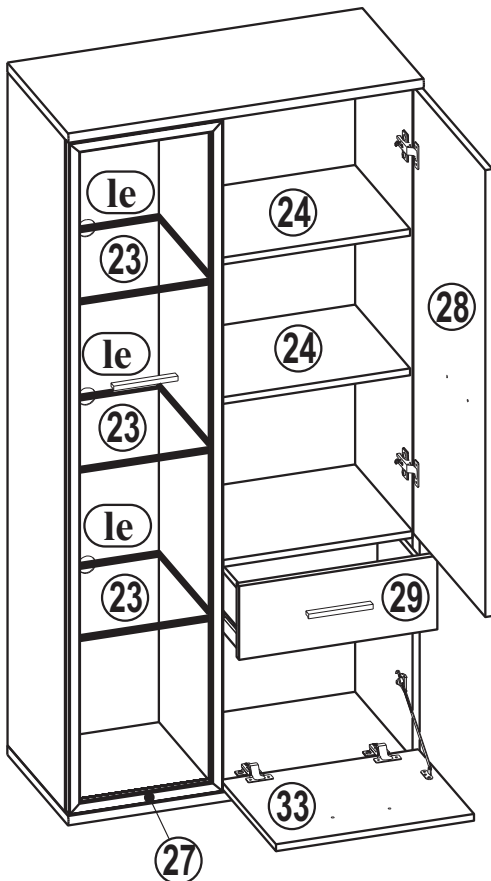
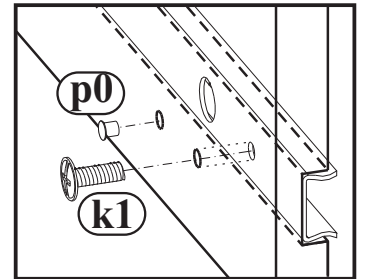
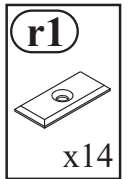
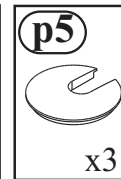
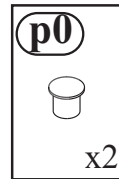
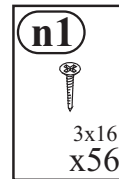
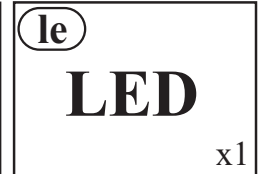
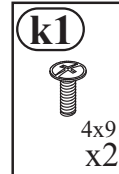
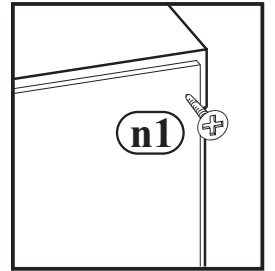
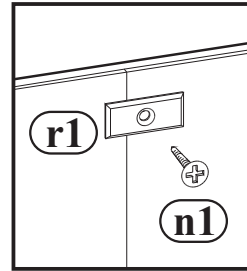
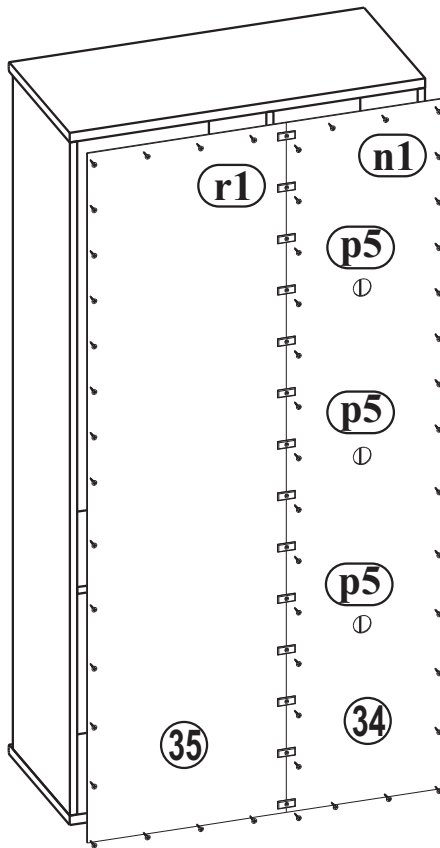

MONTAGEANLEITUNG / SERVICEKARTE

Montageanleitung sollte nicht als technische Dokumentation betrachtet werden. Aufbauänderungen vom Produzenten vorbehalten.

Sehr geehrter Kunde, sollte ein Teil fehlen oder beschädigt sein, kreuzen Sie bitte dieses deutlich auf der SERVICEKARD an und schicken Sie uns die SERVICEKARD zurück.

Den Kleber benutzen Sie nur zum Verleimen der Schubladen.

Um die eventuellen Reklas richtig zu erledigen, bitten wir um eine Kopie des Aufklebers von der Ware, oder um Angabe der Produktionswoche.

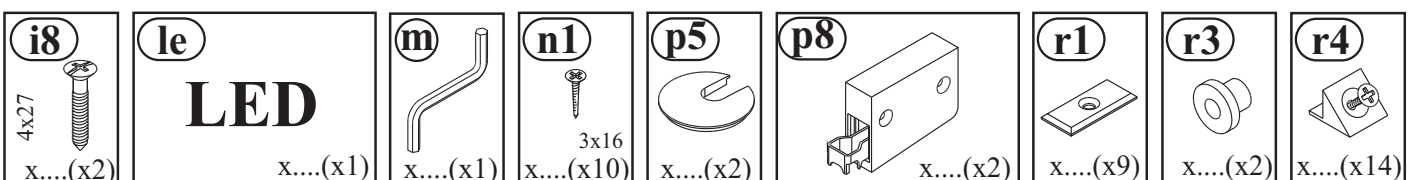
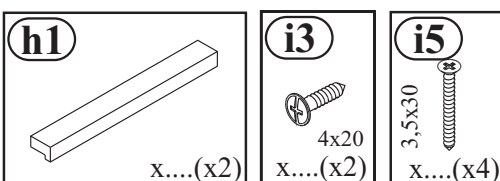
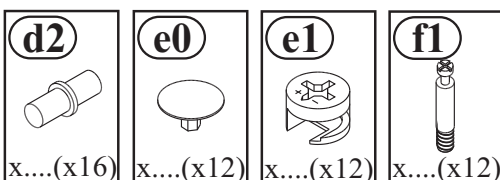
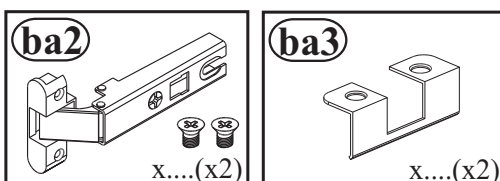
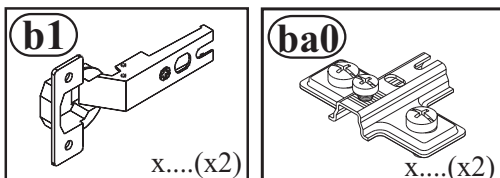
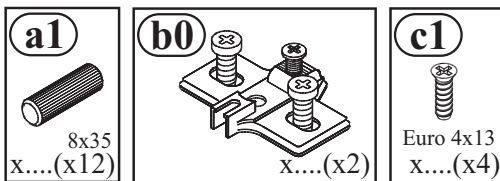
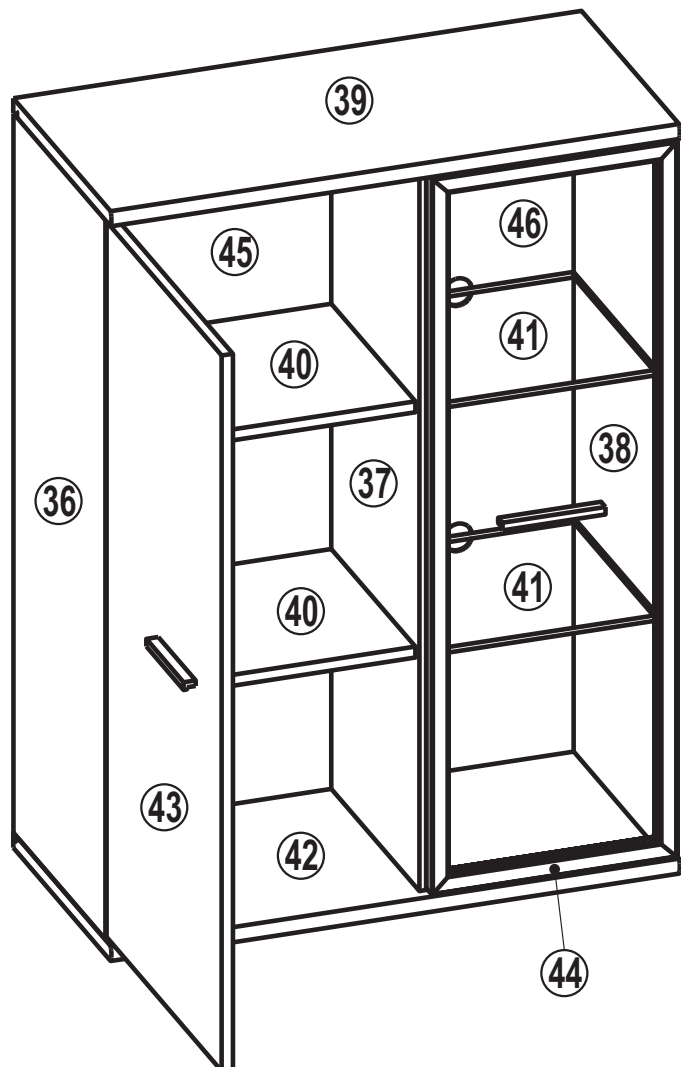
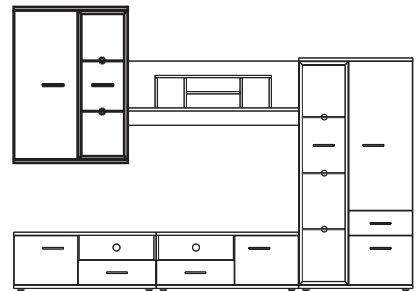

1

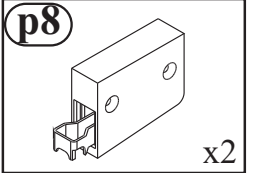
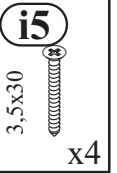
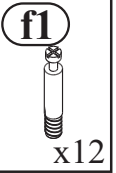
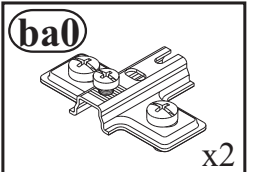
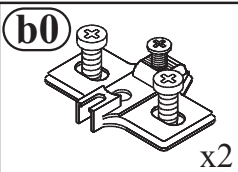
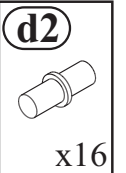
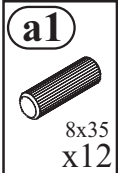
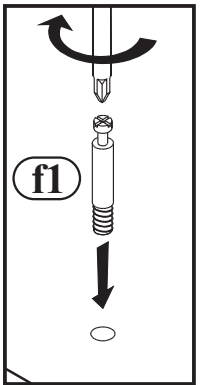
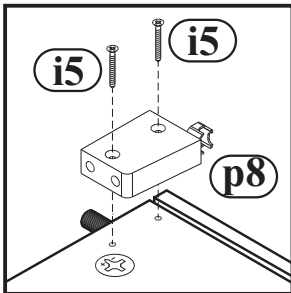
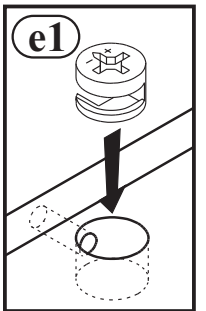
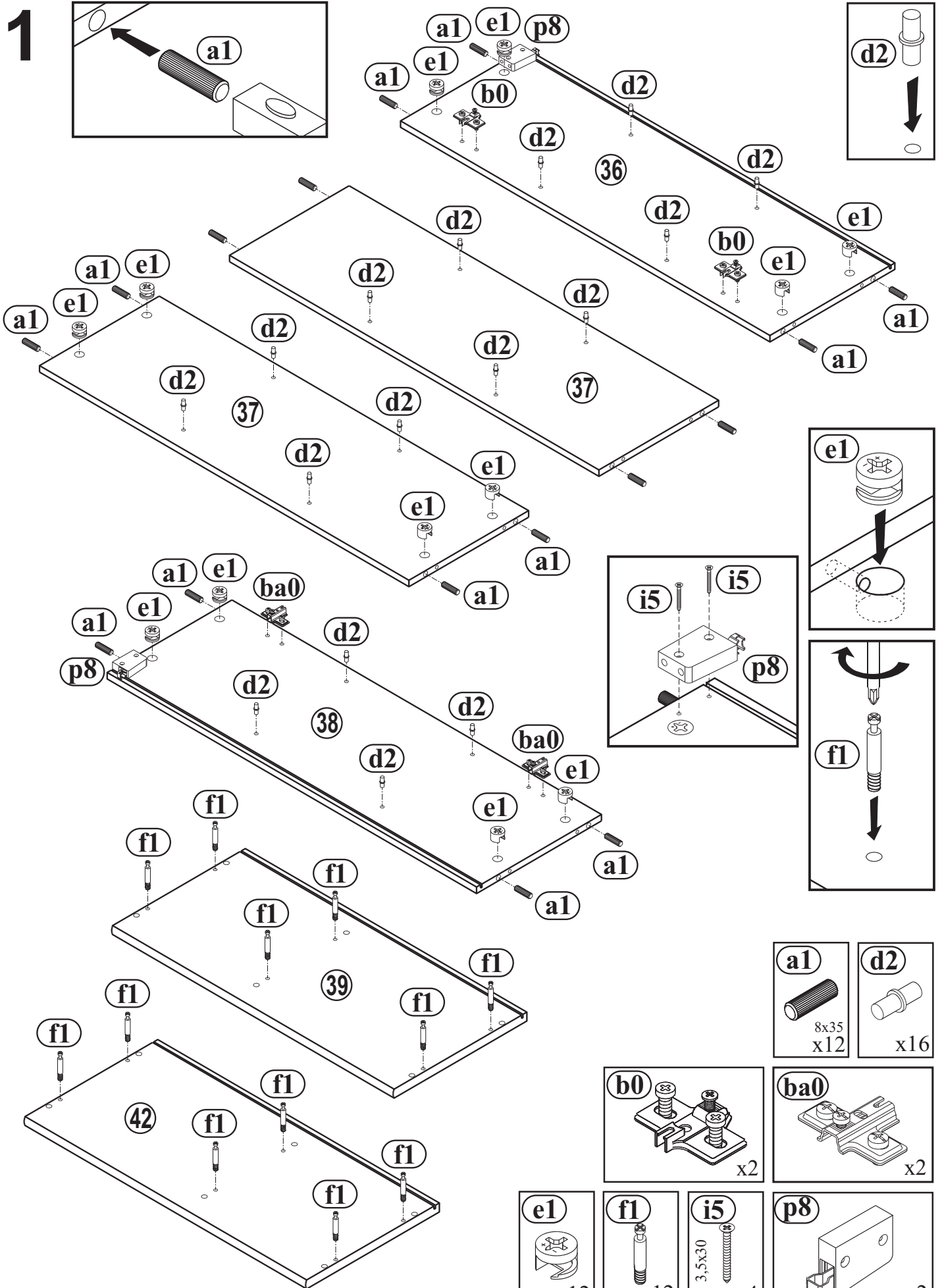
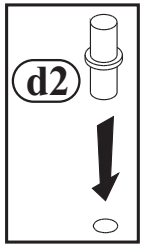
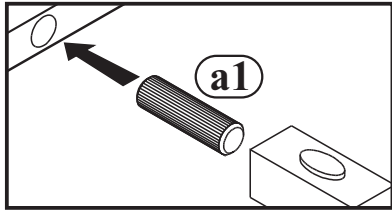

2

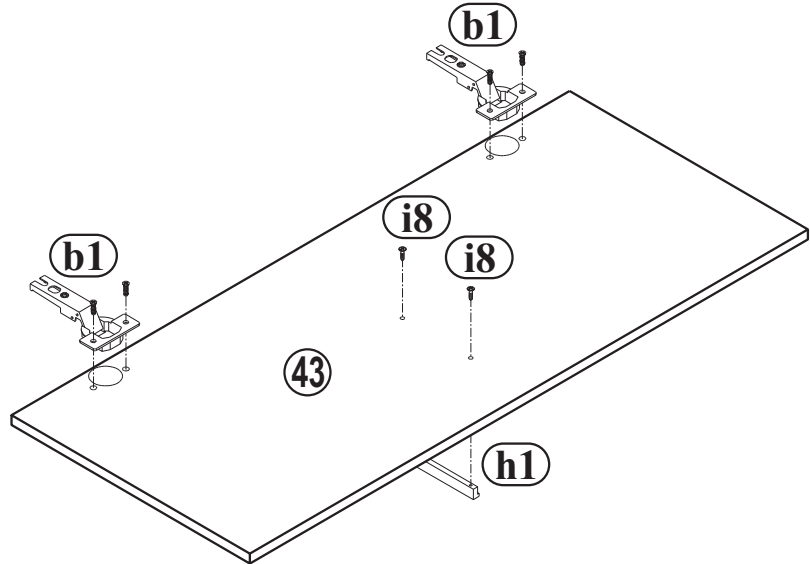
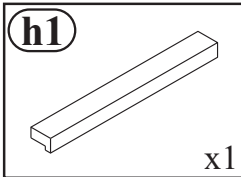
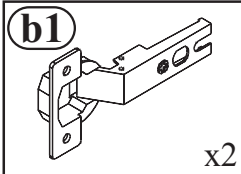
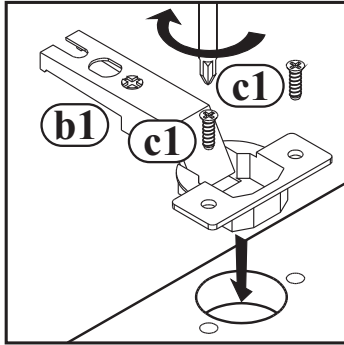

3

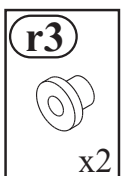
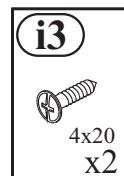
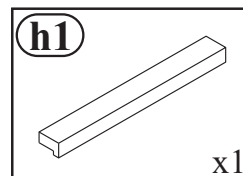
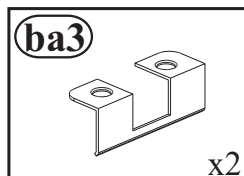
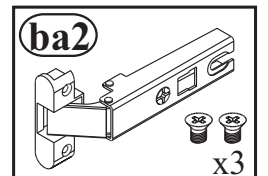
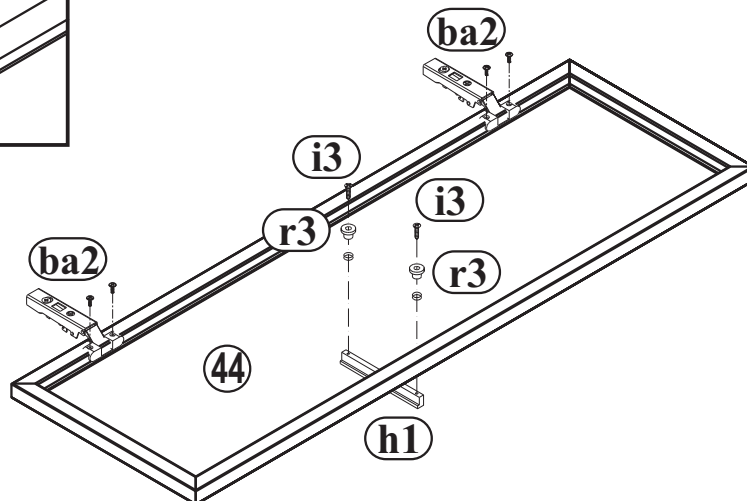
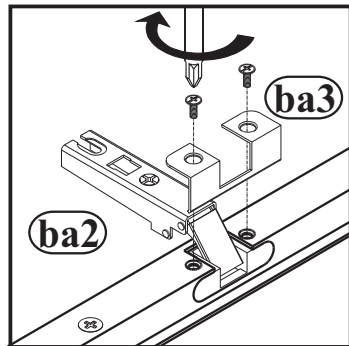

4

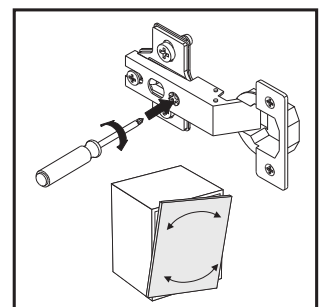
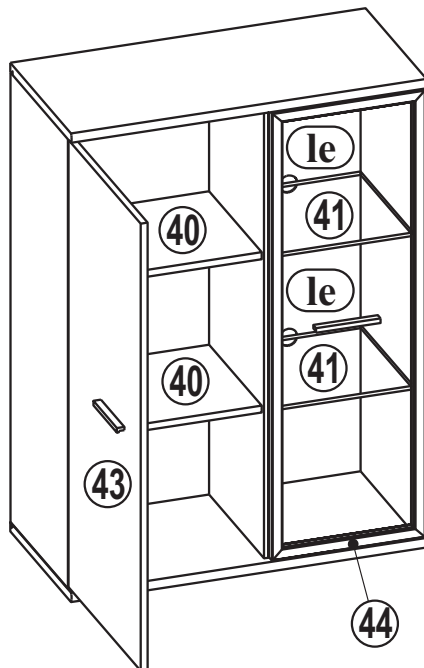
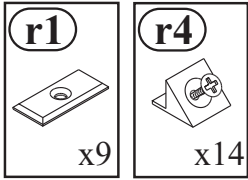
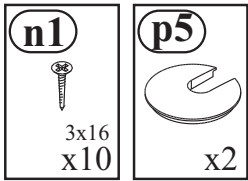
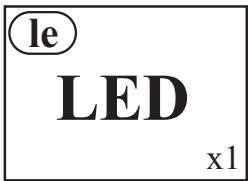
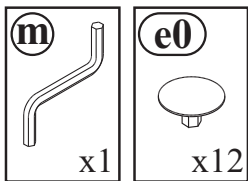
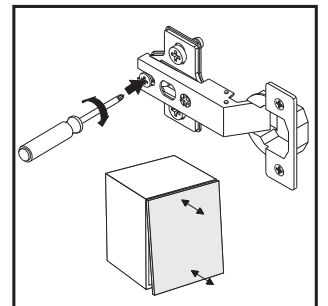
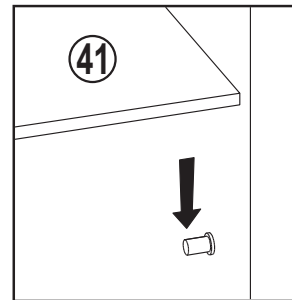
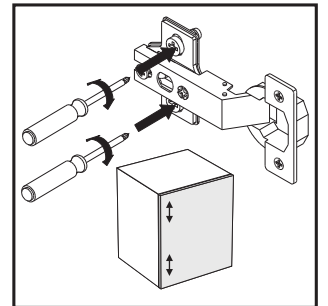
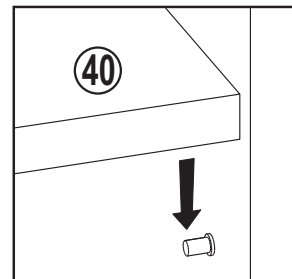
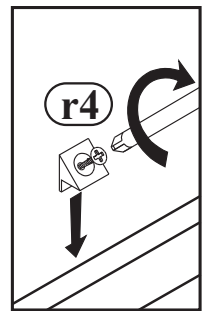
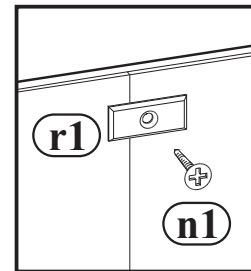
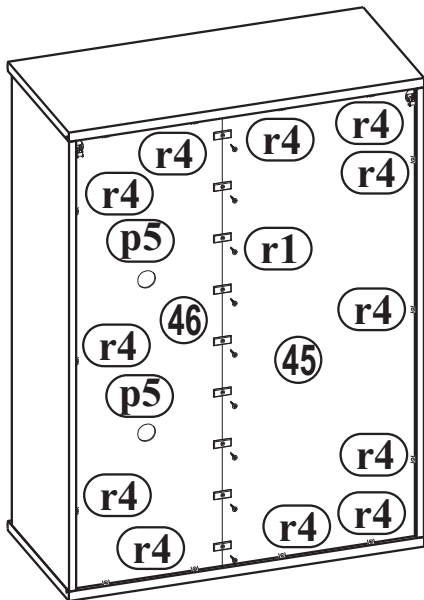
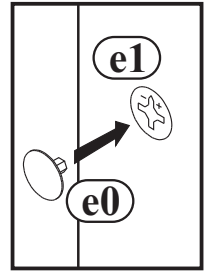
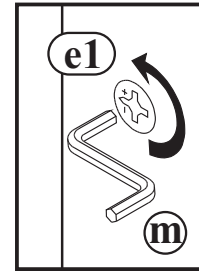
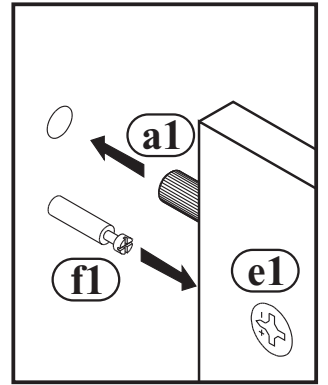
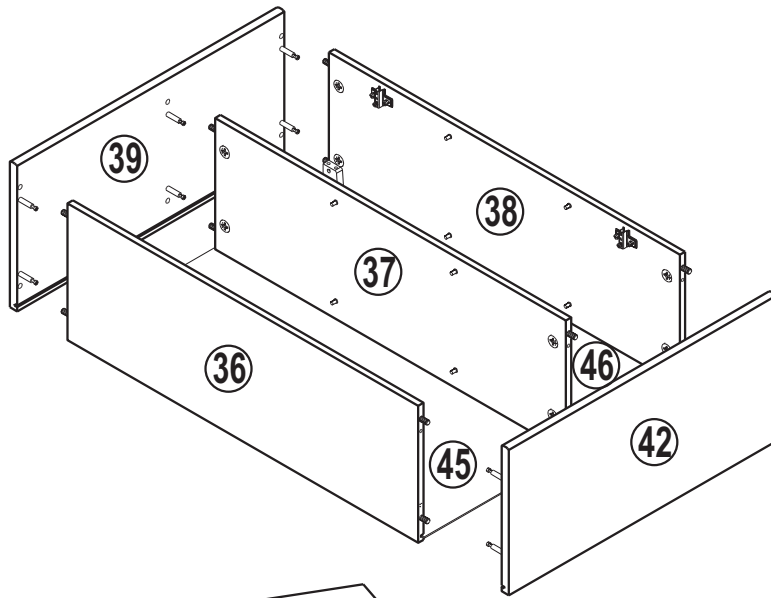

MONTAGEANLEITUNG / SERVICEKARTE

Montageanleitung sollte nicht als technische Dokumentation betrachtet werden. Aufbauänderungen vom Produzenten vorbehalten.

Sehr geehrter Kunde, sollte ein Teil fehlen oder beschädigt sein, kreuzen Sie bitte dieses deutlich auf der SERVICEKARD an und schicken Sie uns die SERVICEKARD zurück.

Den Kleber benutzen Sie nur zum Verleimen der Schubladen.

Um die eventuellen Reklas richtig zu erledigen, bitten wir um eine Kopie des Aufklebers von der Ware, oder um Angabe der Produktionswoche.

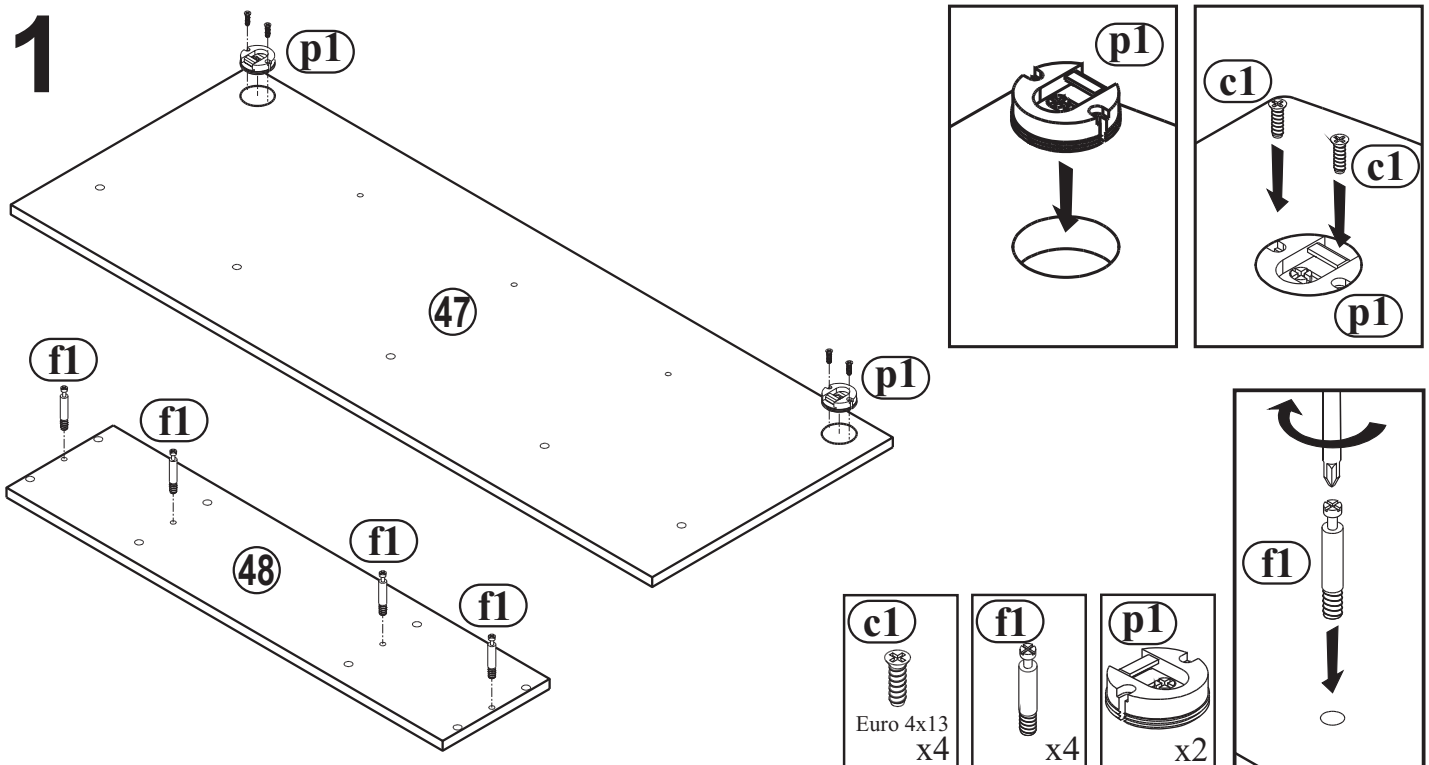
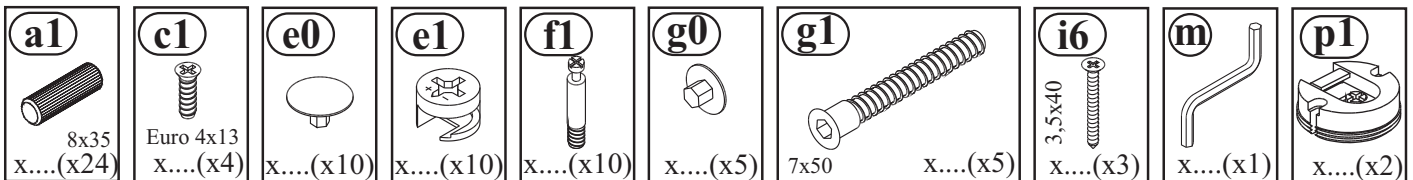
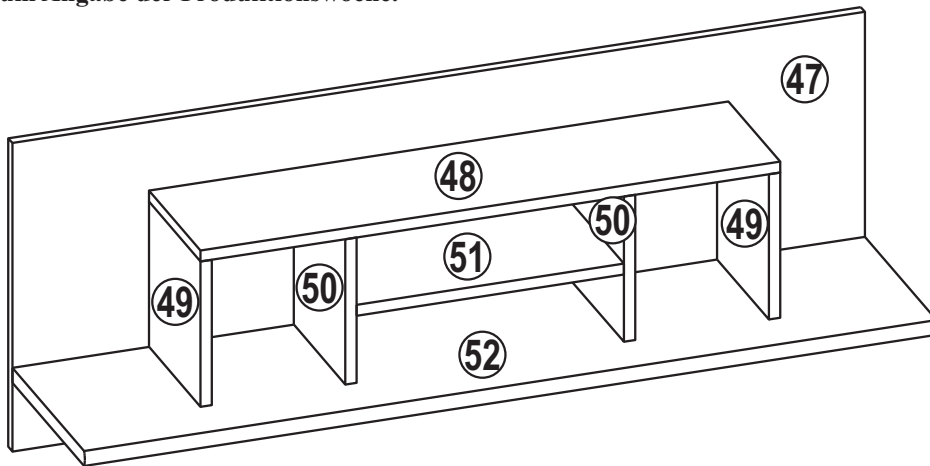
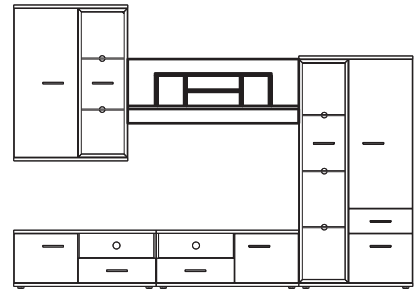

2

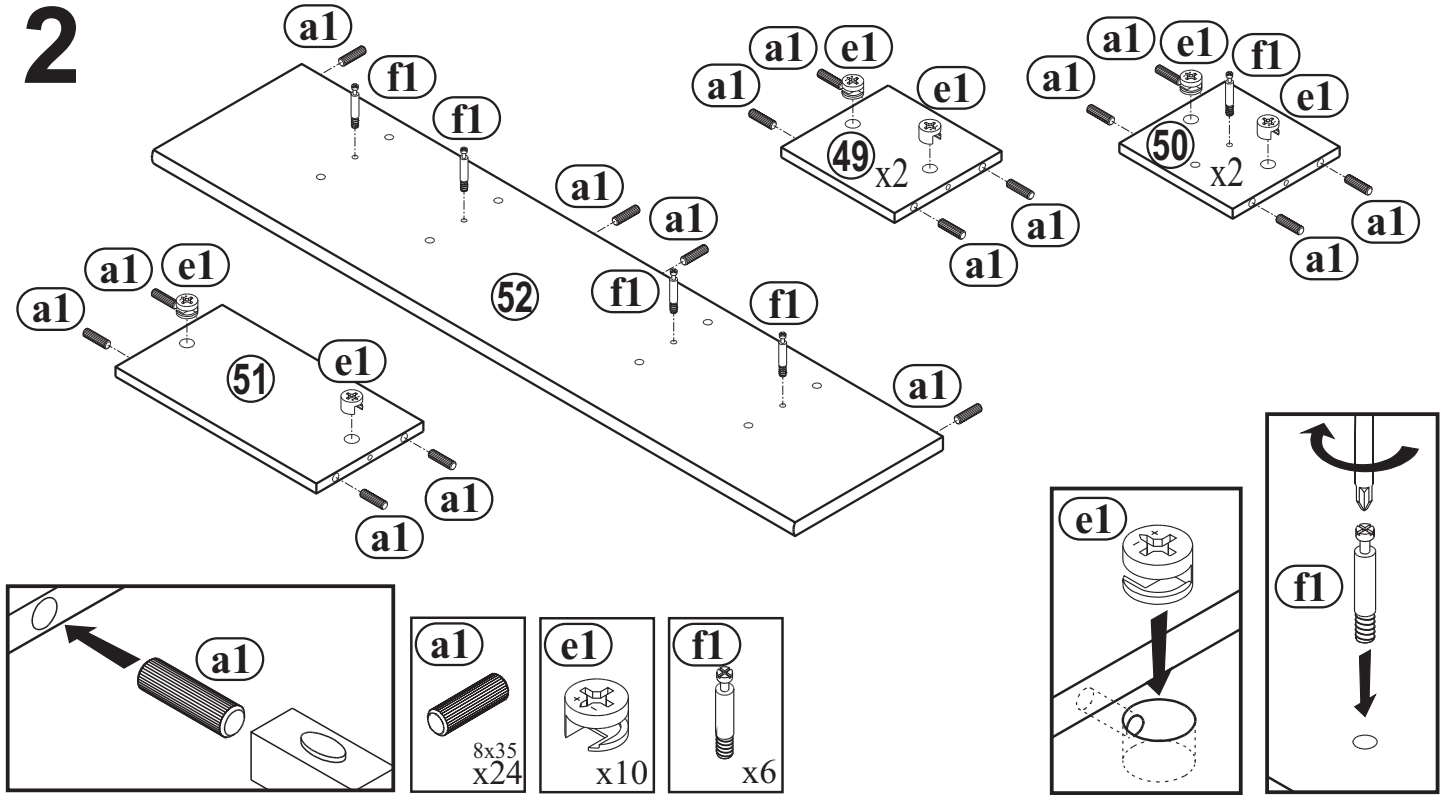

3

