

# 5463A2PM

PARISOT S.A.S. 70800 SAINT LOUP SUR SEMOUSE -FRANCE-



Décor : CHENE BROOKLYN  
Gamme : GALAXY



**Parisot**  
[www.parisot.com](http://www.parisot.com)

## FR Remerciements :

Nous vous remercions d'avoir choisi un meuble créé et fabriqué par le Groupe Pariset et espérons qu'il vous donnera entière satisfaction.

## EN Thanks:

Thank you for choosing furniture designed and manufactured by the Pariset Group. We hope you are totally satisfied with your purchase.

## DE Danksagung:

Wir danken Ihnen für den Kauf eines Frankreich von der Pariset-Gruppe entworfenen und hergestellten Möbelstücks und hoffen, dass Sie es zu Ihrer vollkommenen Zufriedenheit finden werden.

## HU Köszönet.

Köszönjük, hogy a Pariset Groupe által létrehozott és gyártott bútort választott, reméljük, hogy elégedett lesz a termékkel.

## PT Agradecimentos:

Obrigado por ter escolhido um móvel concebido e fabricado pelo Grupo Pariset, esperando que seja do seu inteiro agrado.

## IT Ringraziamenti:

Grazie per avere scelto un mobile progettato e fabbricato dal Gruppo Pariset.

Speriamo soddisfatti appieno le vostre esigenze.

## NL Bedankje:

Wij bedanken u voor de aankoop van een door de Groep Pariset ontworpen en vervaardigd meubel en hopen dat u er veel plezier aan zult beleven.

## CZ Poděkování:

Děkujeme, že jste si vybrali nábytek navržený a vyrobený společností Pariset Group. Doufáme, že budete svým nákupem naprosto spokojeni.

## ES Agradecimientos:

Les damos las gracias por haber elegido un mueble diseñado y fabricado por el Grupo Pariset y esperamos que sea de su total agrado.

## PL Podziękowania:

Dziękujemy za wybór mebli stworzonych i wyprodukowanych przez Grupę Pariset. Mamy nadzieję, że będziecie Państwo w pełni zadowoleni z zakupu.

## RO Mulțumiri:

Vă mulțumim că ați ales un articol de mobilier conceput și fabricat de Grupul Pariset și sperăm că veți fi pe deplin satisfăcuți de acesta.

## RU Благодарность:

Мы благодарим вас за то, что вы выбрали мебель, созданную и произведенную Групп Паризо, и надеемся, что вы будете полностью удовлетворены нашей продукцией.

## SK Pod'akovanie:

Ďakujeme, že ste si vybrali nábytok navrhnutý a vyrobený spoločnosťou Pariset Group. Dúfame, že budete svojim nákupom absolútne spokojní.

## TR Teşekkür ederiz:

Pariset Group tarafından tasarlanan ve üretilen bu mobilyayı seçtiğiniz için teşekkür ederiz. Ürünümüzden memnun kalmanızı ümit ederiz.

## ZH 感谢 :

感谢您选择帕里索集团设计制造的家具。我们希望您对此次购买十分满意、

## AR : شكر

نشكركم لاختياركم هذه القطعة من الأثاث من تصميم وتصنيع مجموعة باريزو Pariset ونتمنى أن تتلأ رضاءكم.

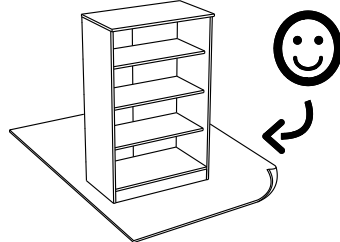
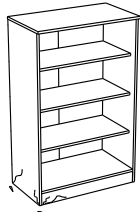
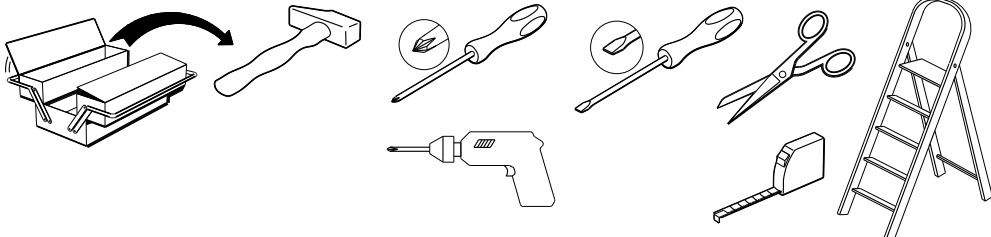

[contact@pariset.com](mailto:contact@pariset.com)



[www.parisot.com](http://www.parisot.com)

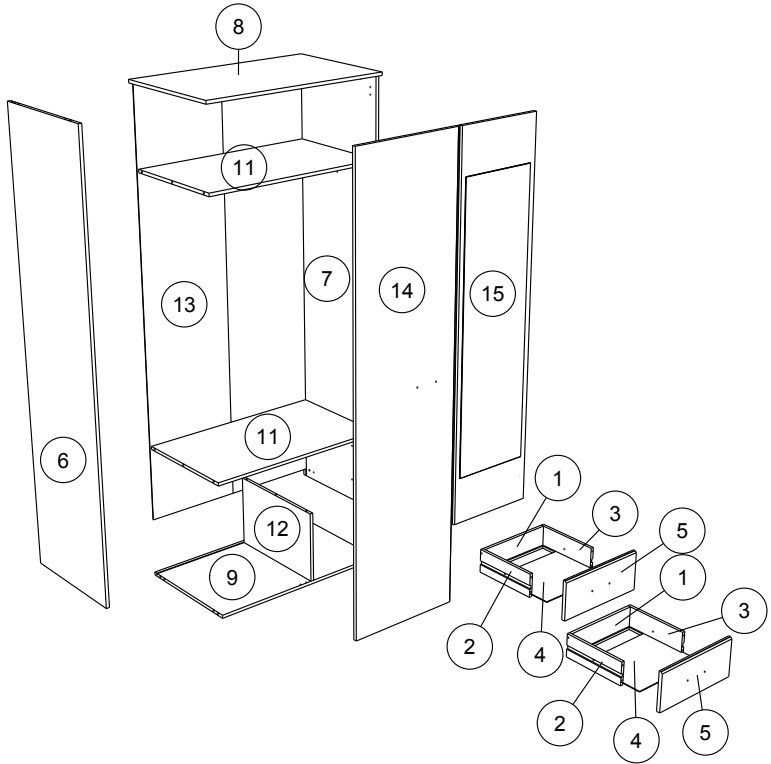
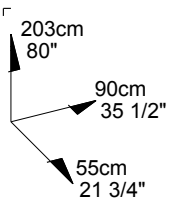

		mm			inch		
5	x 2	391	167	15	15 3/8	6 9/16	9/16
12	x 1	508	334	15	20	13 1/8	9/16
11	x 2	867	508	15	34 1/8	20	9/16
9	x 1	867	528	15	34 1/8	20 13/16	9/16
8	x 1	899	550	15	35 3/8	21 5/8	9/16
15	x 1	1622	393	15	63 7/8	15 1/2	9/16
14	x 1	1962	500	15	77 1/4	19 11/16	9/16
6	x 1	2013	529	15	79 1/4	20 13/16	9/16
7	x 1	2013	529	15	79 1/4	20 13/16	9/16
3	x 2	275	100	13	10 13/16	3 15/16	1/2
2	x 2	275	100	13	10 13/16	3 15/16	1/2
1	x 2	329	100	13	12 15/16	3 15/16	1/2
4	x 2	341	275	3	13 7/16	10 13/16	1/8
13	x 1	1984	883	3	78 1/8	34 3/4	1/8

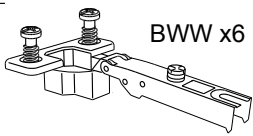

BWW x6

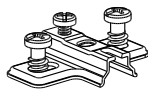

BWU x6



EP x3



Ai x14

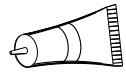

CF x1

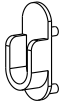

GZ x2

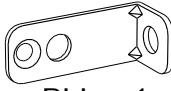

BLL x1

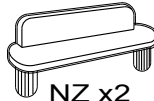

NZ x2



BSM x2



DC x1

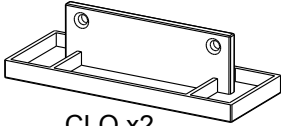

CLO x2

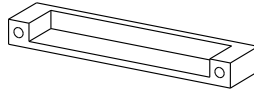

POI x3



CG x4

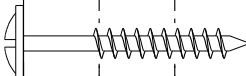
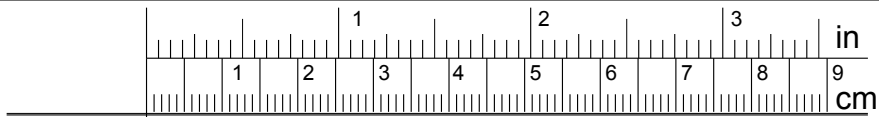

WH x 6



ADU x12

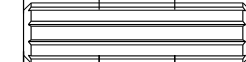

ADM x20

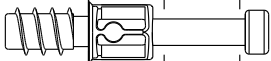

BSD x 14

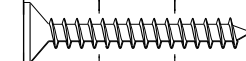

WF x 4

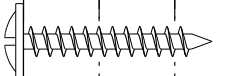

XN x 2



VE x6



VG x 3

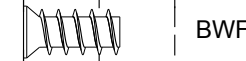

BWF x 8



ANK x2



VR x4

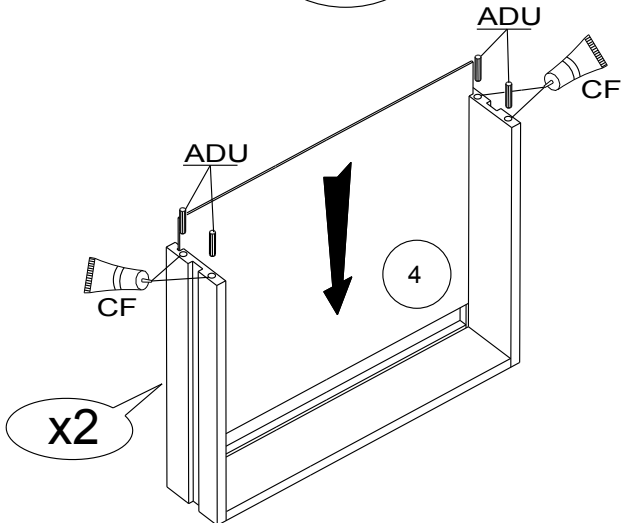
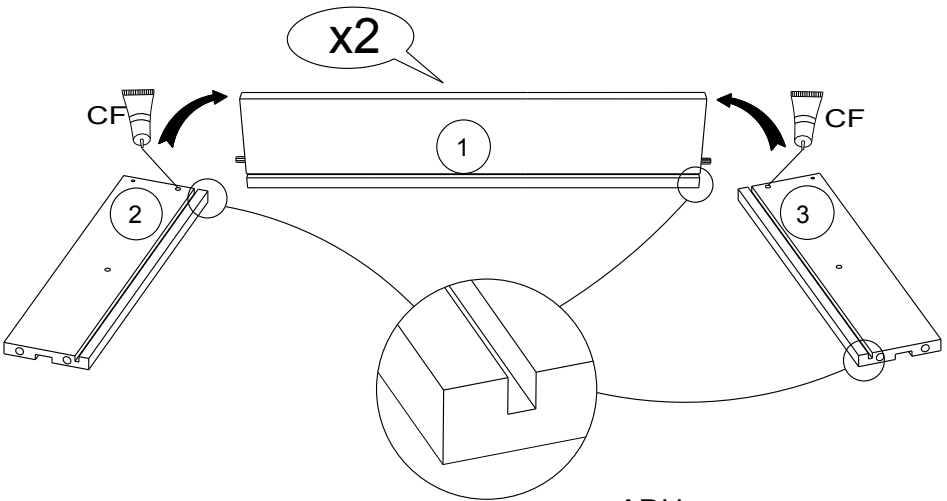
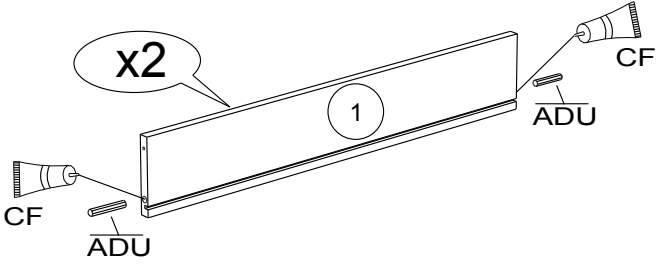
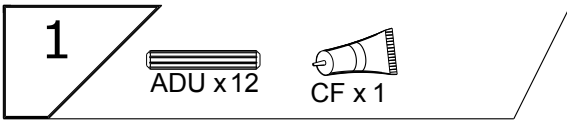

2

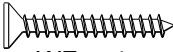

WF x 4



POI x2

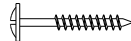

WH x 4

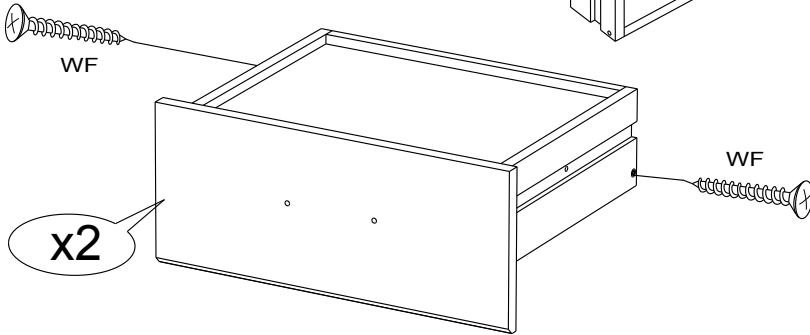
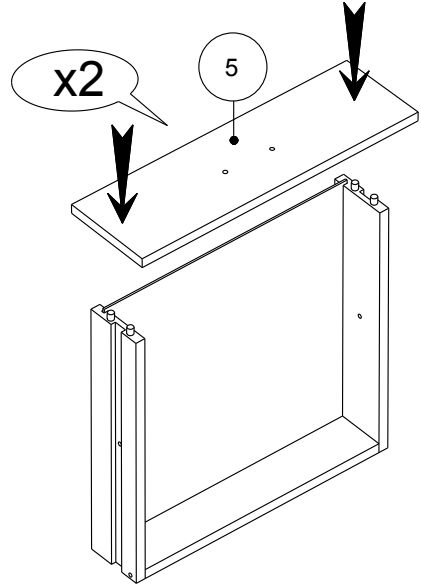
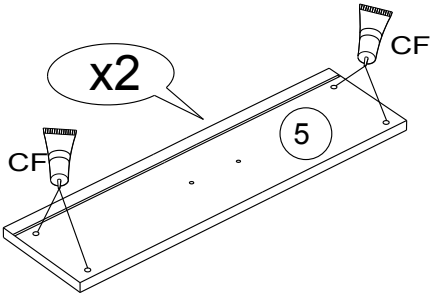

POI

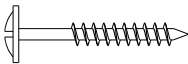

WH

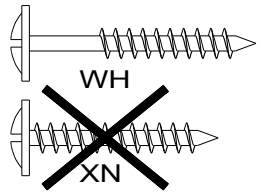

WH

XN

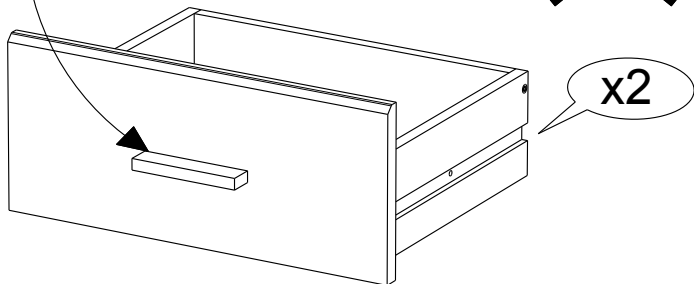

3

ADM x2

BSD x 4

BWU x3

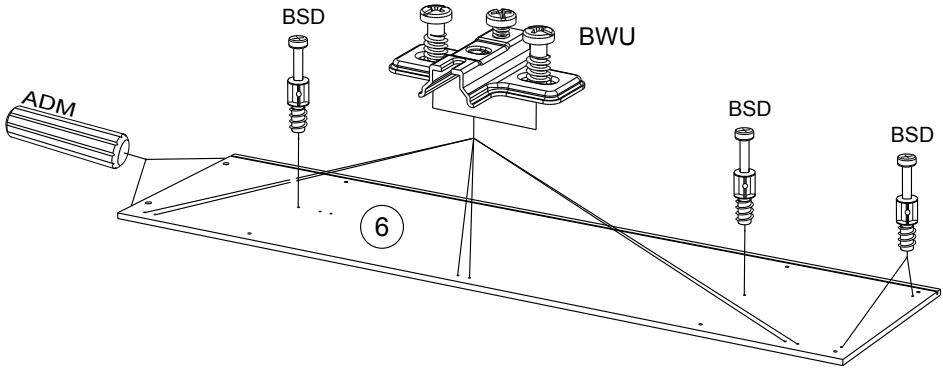

4

ADM x2

BSD x 4

BWU x3

CG x 2

BWF x 4

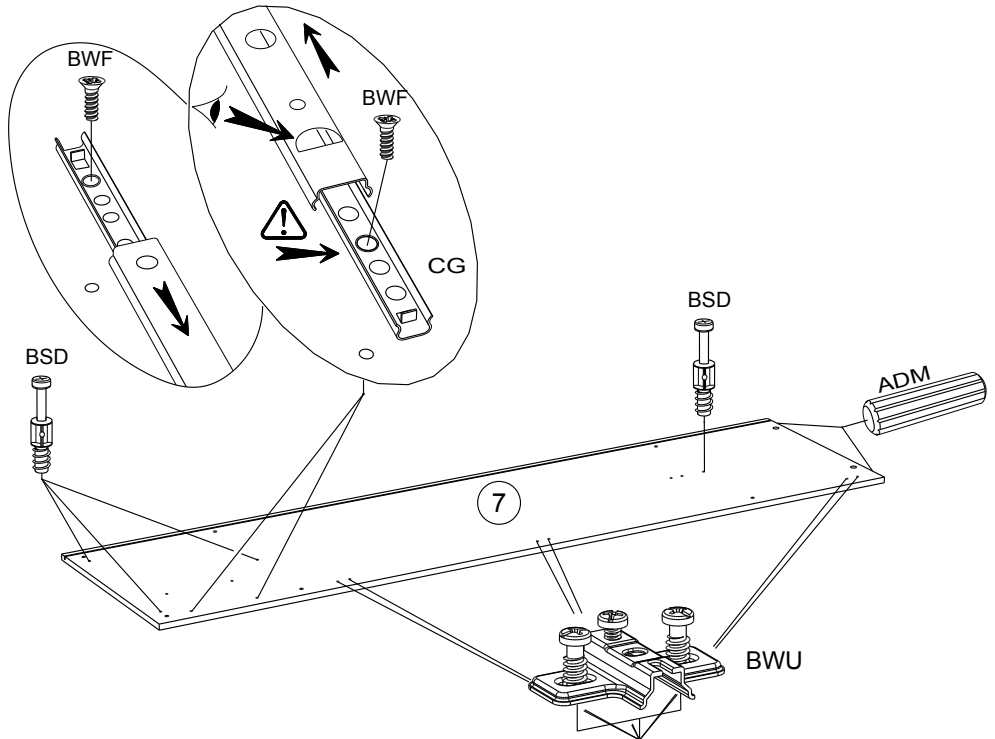

5

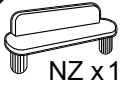

NZ x1



BSD x 4

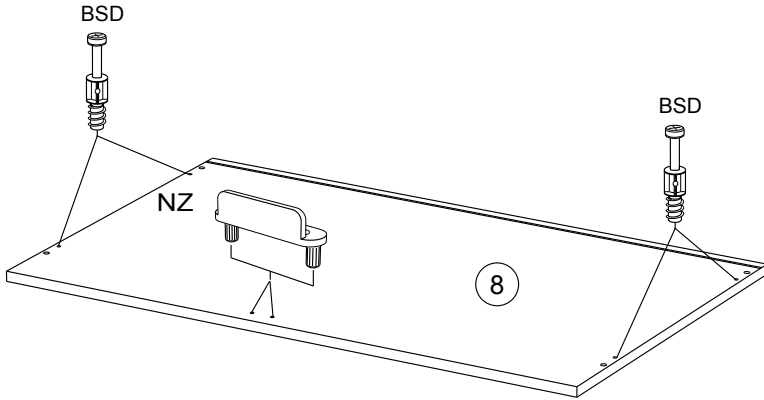

6

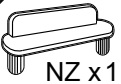

NZ x1



ADM x4



ANK x 2



BSD x 1

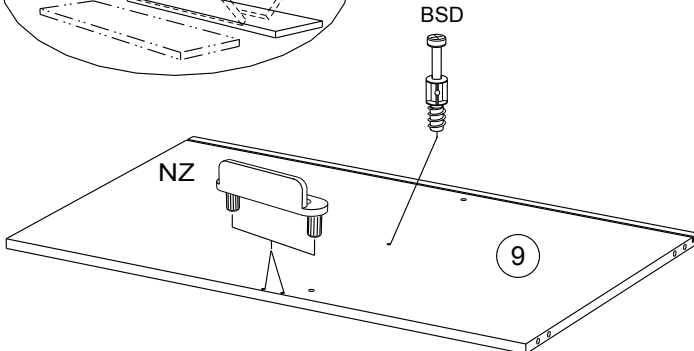
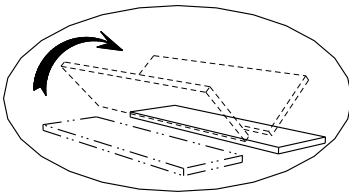
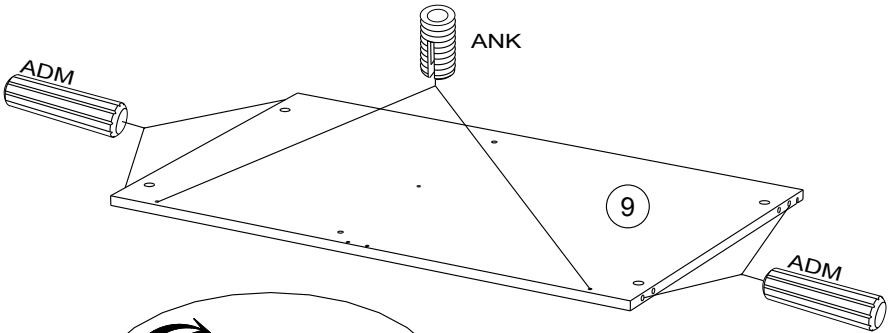



7

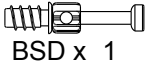

BSD x 1



ADM x 4

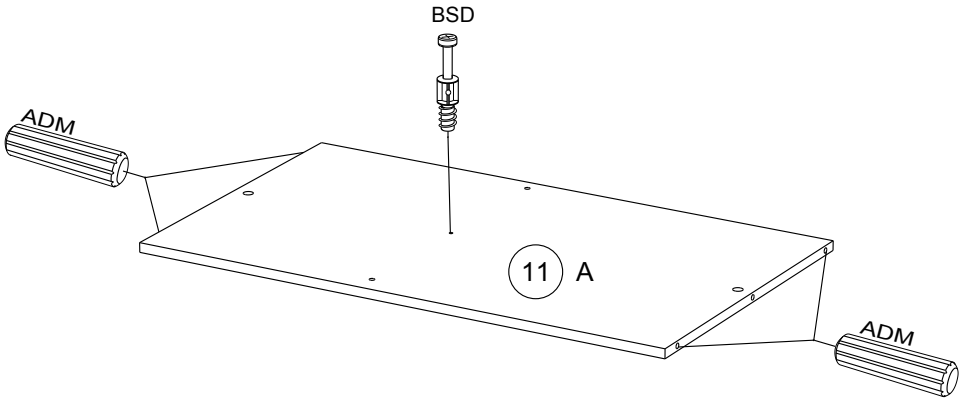

8



ADM x 4

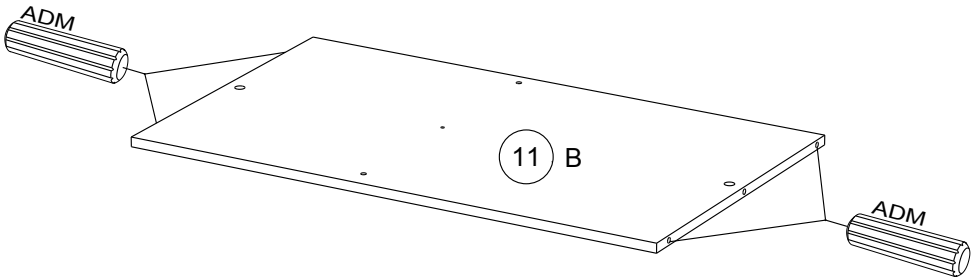

9



ADM x 4

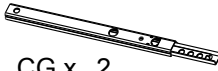

CG x 2



BWF x 4

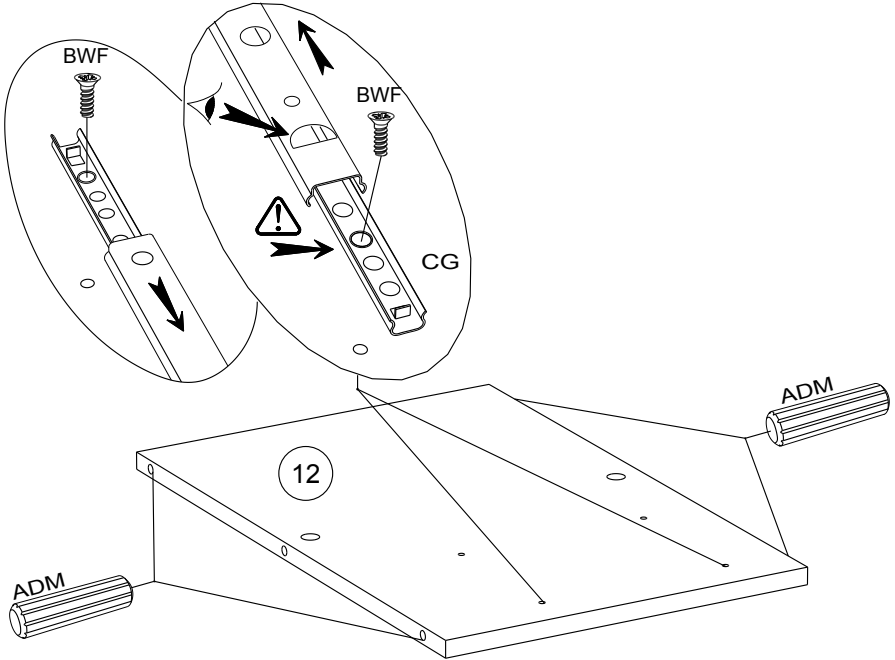

10



Ai x 2

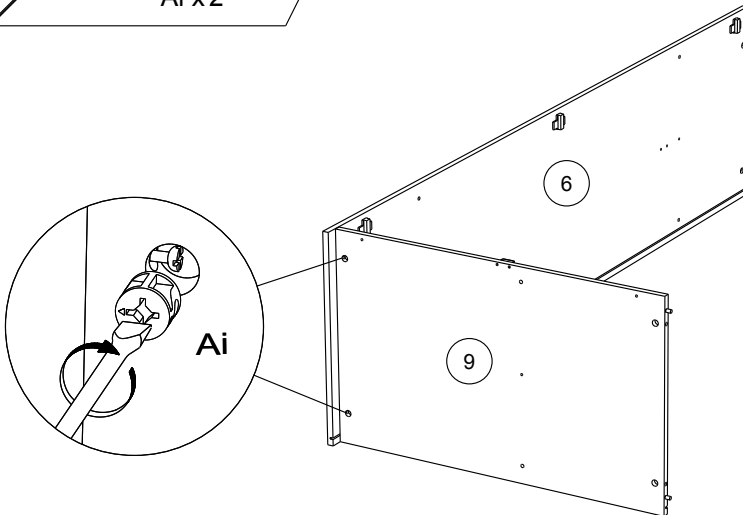

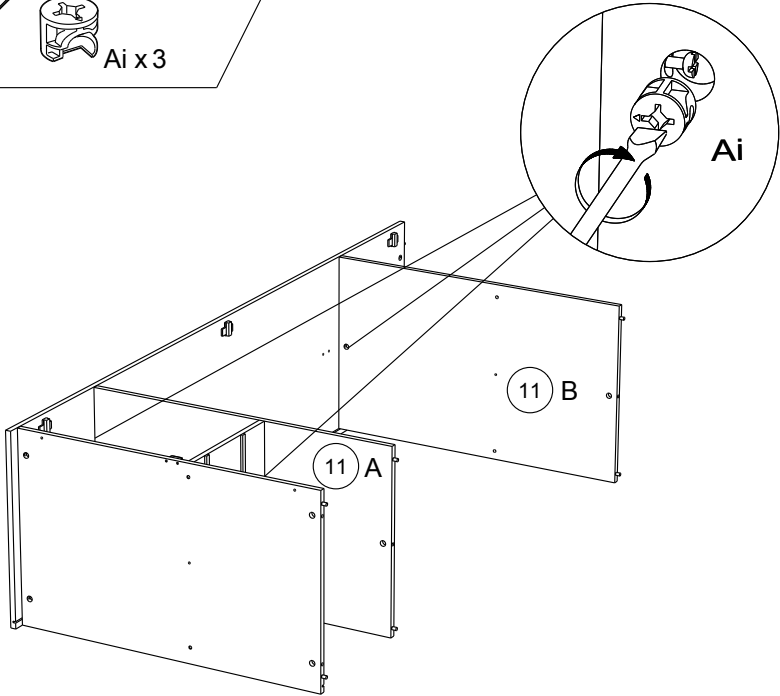
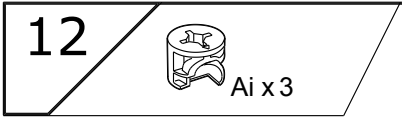
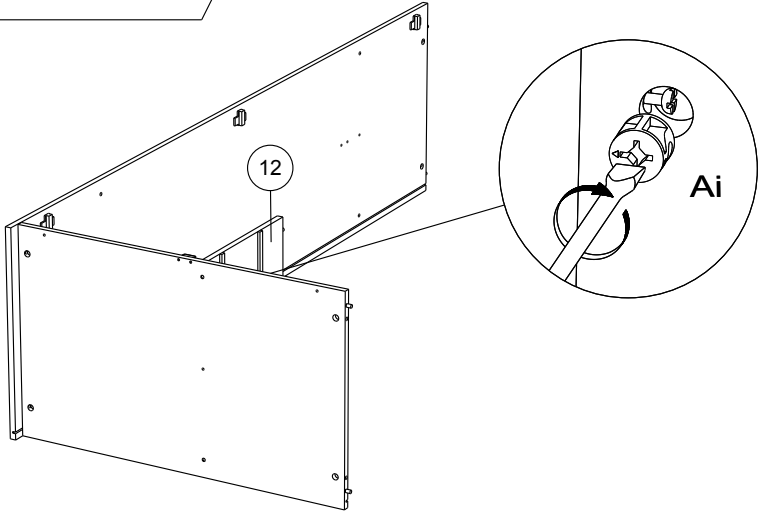

13



Ai x 4

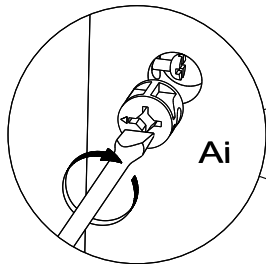

Ai

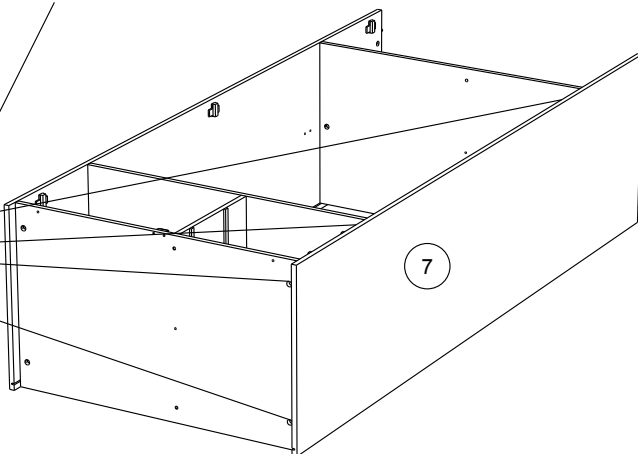

14

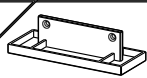

CLO x 2

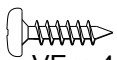

VE x 4



BSM x 2

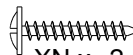

XN x 2

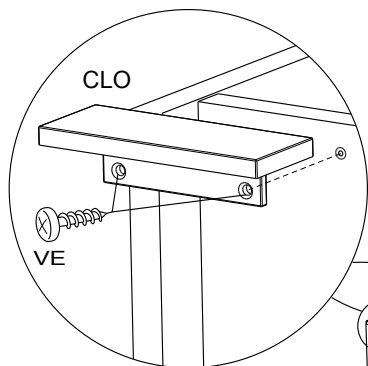

CLO

VE

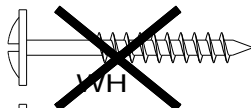
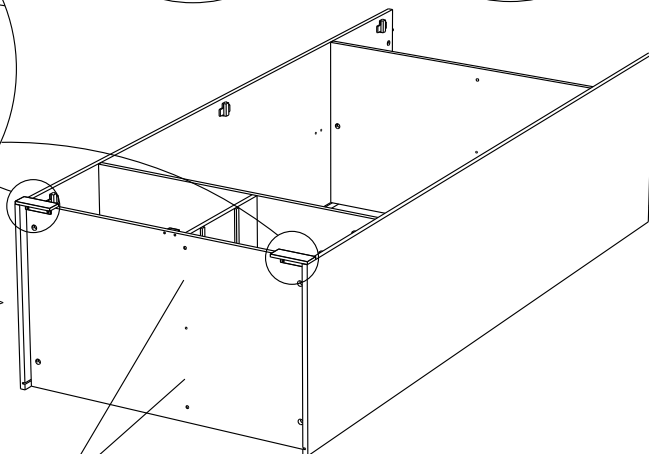
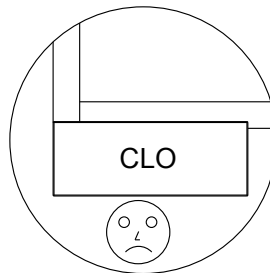
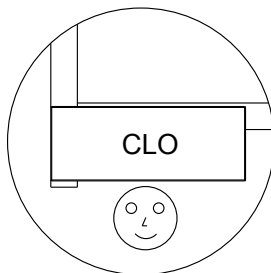

VH

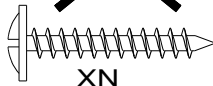

XN

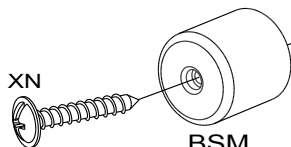

XN

BSM

15

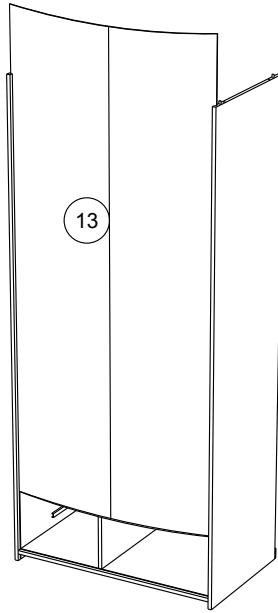

16



Ai x 4

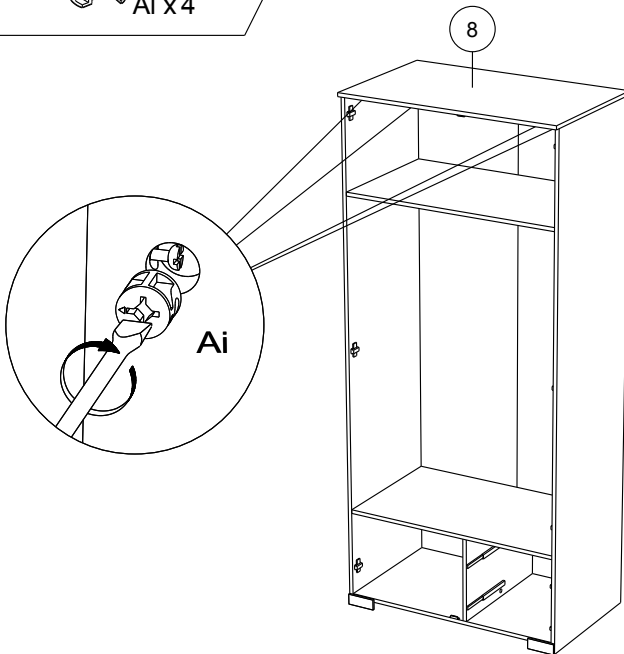

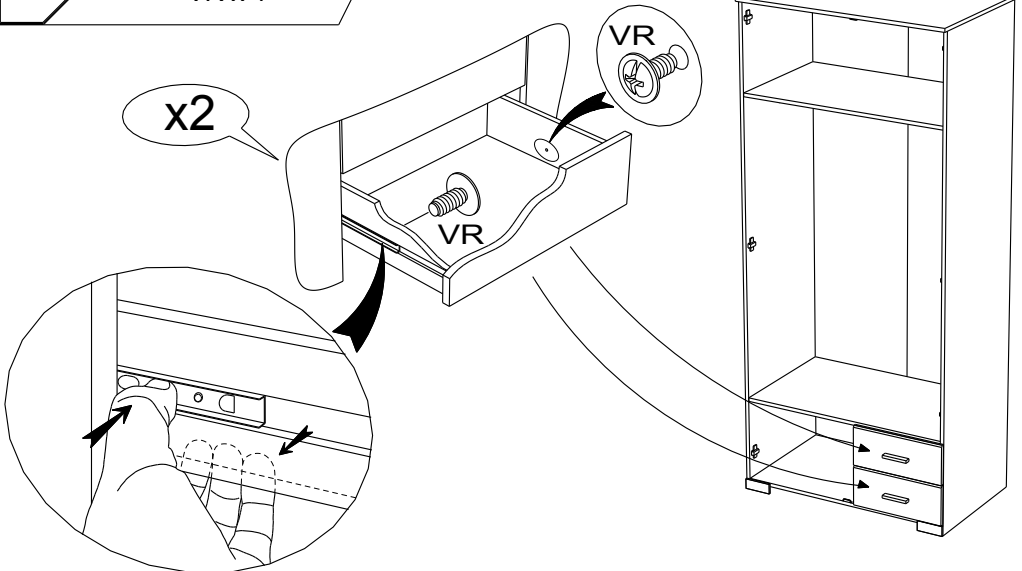
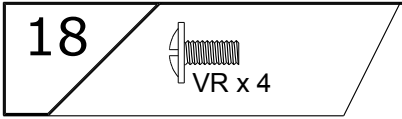
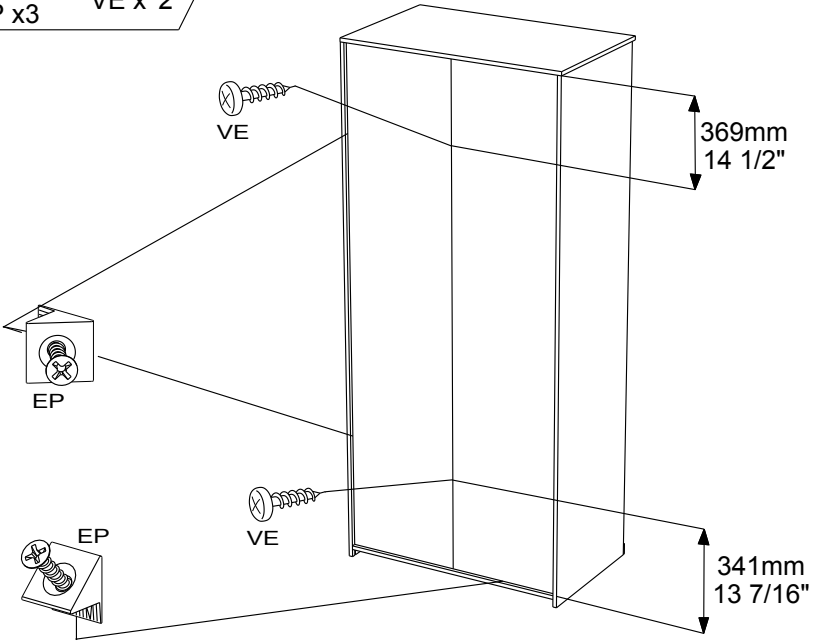
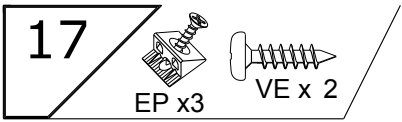

**FR** Pour votre sécurité : Fixation du meuble au mur

Attention, la fixation doit être réalisée par une personne compétente car cela nécessite des chevilles adaptées à la nature de votre mur.

**EN** For your safety: the unit should be secured to the wall.

NB this should be carried out by a competent person as you must use the right rawplug for your type of wall.

**DE** Zu Ihrer Sicherheit: Befestigen Sie das Hochbett an der Wand.

Achtung: Diese Befestigung ist durch eine fachlich kompetente Person vorzunehmen. Hierfür sind für die Bauweise Ihrer Wand geeignete Dübel einzusetzen.

**ES** Por su seguridad: Fijar el mueble a la pared.

Advertencia: la fijación la ha de llevar a cabo por personal adecuado, ya que requiere el uso de tacos que se adapten al tipo de pared.

**PT** Para sua segurança: fixação do móvel ao muro

Atenção: a fixação deverá ser efetuada por pessoa habilitada, visto que são necessárias cavilhas adaptadas ao tipo de parede.

**IT** Avvertenza di sicurezza: il fissaggio del mobile a parete deve essere realizzato da una persona competente, in quanto l'operazione richiede l'impiego di tasselli adatti alla natura del muro.

**NL** Voor uw veiligheid: bevestiging van het meubel aan de muur.

Opgelet de bevestiging moet worden uitgevoerd door een bekwaam persoon daar dit voor uw type muur geschikte pluggen vereist.

**CZ** Z bezpečnostních důvodů: upevněte nábytek do zdi

Pozor, upevnění je třeba svěřit kompetentní osobě, neboť vyžaduje hmoždinky vhodné pro vaši zeď.

**HU** Az Ön biztonsága érdekében : a bútor falra rögzítése

Figyelmeztetés : a rögzítés csak megfelelő szakképesítéssel rendelkező személy által végezhető el, mert a rögzítéshez a falnak megfelelő csavarokra van szükség.

**PL** Dla bezpieczeństwa: mocowanie mebla do ściany

Uwaga, mocowanie musi zostać wykonane przez osobę kompetentną, ponieważ wymaga to zastosowania kołków dostosowanych do rodzaju ściany.

**RO** Pentru securitatea dumneavoastră: fixarea mobilierului de perete

Atenție, fixarea trebuie să fie realizată de o persoană calificată, deoarece sunt necesare dispozitive de fixare adaptate caracteristicilor peretelui dumneavoastră

**RU** Для вашей безопасности: Крепление мебели к стене

Внимание! Крепление должно производиться опытным специалистом, т.к. для такой установки потребуются штифты, соответствующие типу вашей стены.

**SK** Z bezpečnostných dôvodov: nábytok upevnite k stene.

Dbajte na to, aby upevnenie vykonala kompetentná osoba, pretože pri upevňovaní sa vyžadujú kolíky vhodné do materiálu, z ktorého je stena vyrobená.

**TR** Güvenliğiniz için: Mobilyanın duvara sabitlenmesi

Dikkat, sabitleme işlemi uzman biri tarafından yapılmalıdır çünkü bu işlem için duvarınızın malzemesine uygun dübellerin kullanılması gerekmektedir

**GR** Για την ασφάλειά σας : στερέωση των επίπλων στον τοίχο.

Προσοχή, η στερέωση πρέπει να γίνεται από ικανό άτομο, καθώς απαιτούνται σφίγγες προσαρμοσμένες στη φύση του τοίχου σας.

اللغة العربية

لسلامتكم الشخصية: تثبيت قطعة الأثاث على الحائط

تحذير، يجب أن يقوم شخص متخصص بعملية التثبيت على الحائط إذ أنها تتطلب اسفينا معنا يتوافق مع طبيعة الحائط نفسه.

**ZH** 为了您的安全：本产品必须靠墙安装。

NB 本产品必须由专业人士安装，且您必须使用符合您的墙壁类型的罗威纤维管。

19



BLL x1



VG x3



GZ x2



DC x1

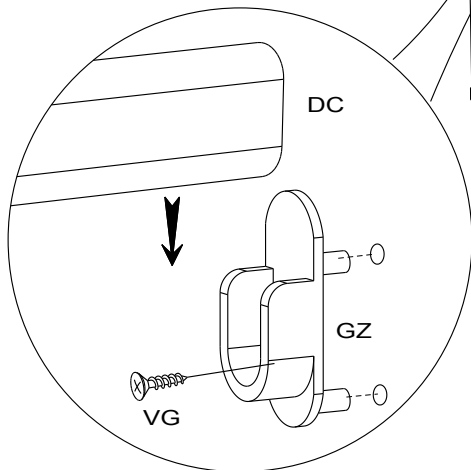
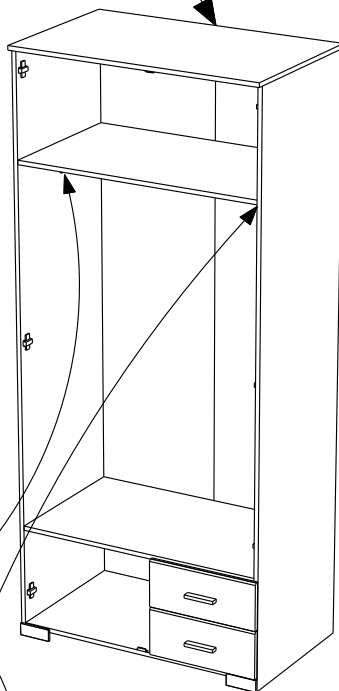
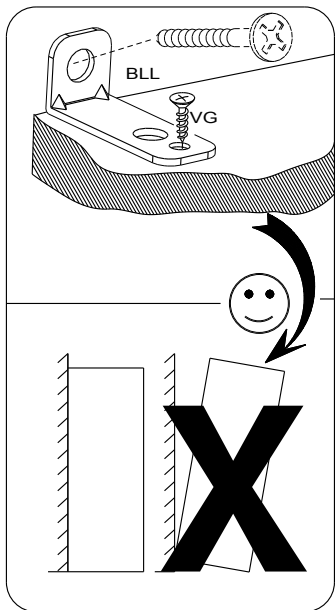



20

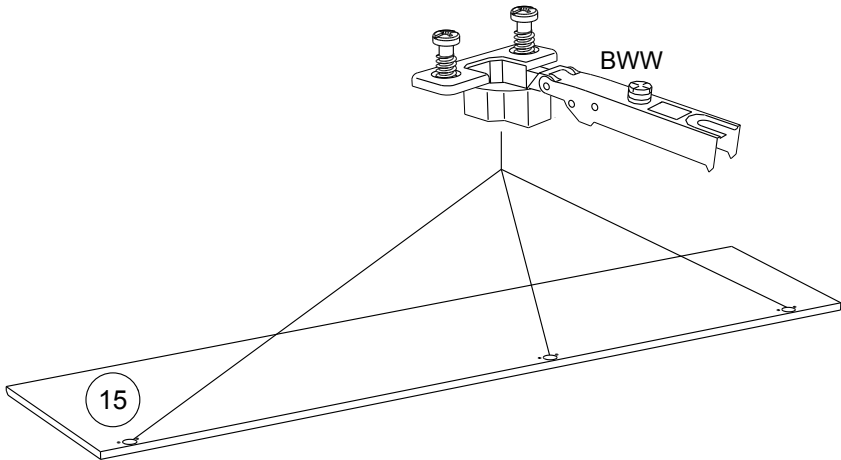
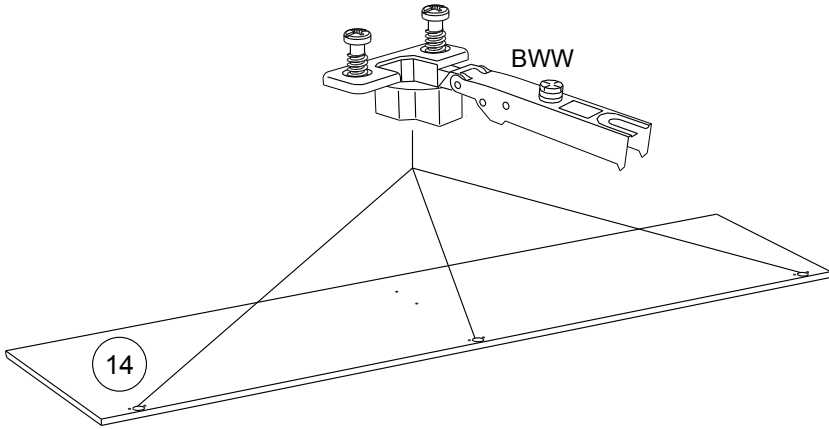
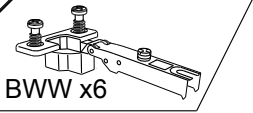

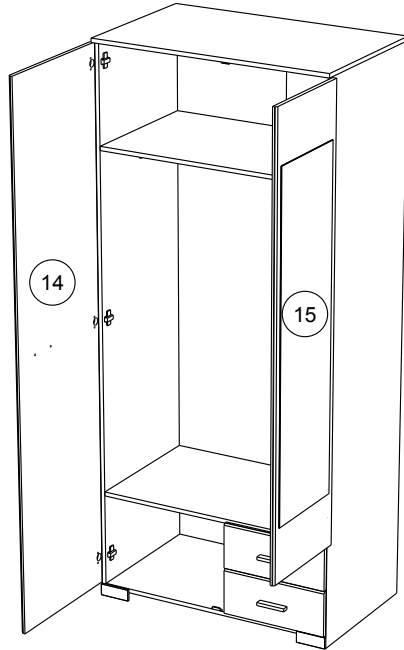

**RCH-N**

**MONTAGE**

- Ⓒ GB LEAFLET
- Ⓓ D AUFBAUANLEITUNG
- Ⓔ E MONTAJE
- Ⓟ P MONTAGEM
- Ⓜ I MONTAGGIO
- Ⓝ NL MONTAGE

**REGLAGE** Ⓒ GB ADJUSTING   Ⓔ E AJUSTER   Ⓜ I AGGIUSTAMENTO  
 Ⓓ D ANPASSUNG   Ⓟ P REGULACAO   Ⓝ NL AFSTELLING

22



POI x1

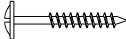

WH x 2

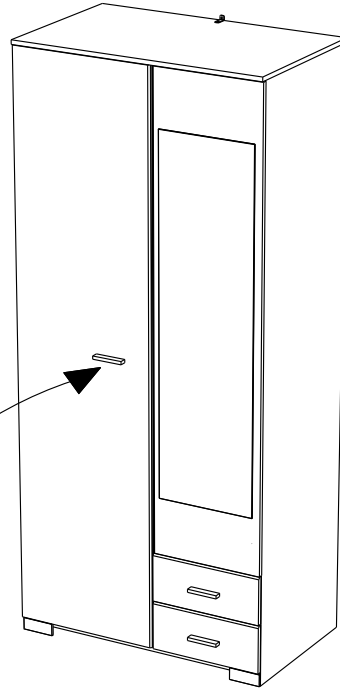

POI

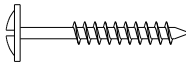

WH

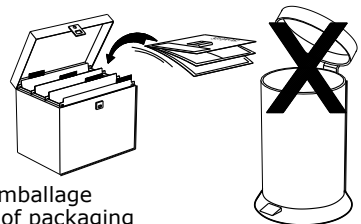

Faites un geste pour l'environnement en triant vos déchets d'emballage  
Make a gesture for the environment by sorting out your waste of packaging  
Machen Sie eine Bewegung für die Umwelt, ihre Verpackungsabfälle sortierend  
Haga un gesto para el medio ambiente escogiendo sus residuos de embalaje